

# **Capitolul 3**

## **Surse de curent si surse de tensiune**

## **3.1. Surse de curent**

# 3.1. Surse de curent

## 3.1.1. Introducere

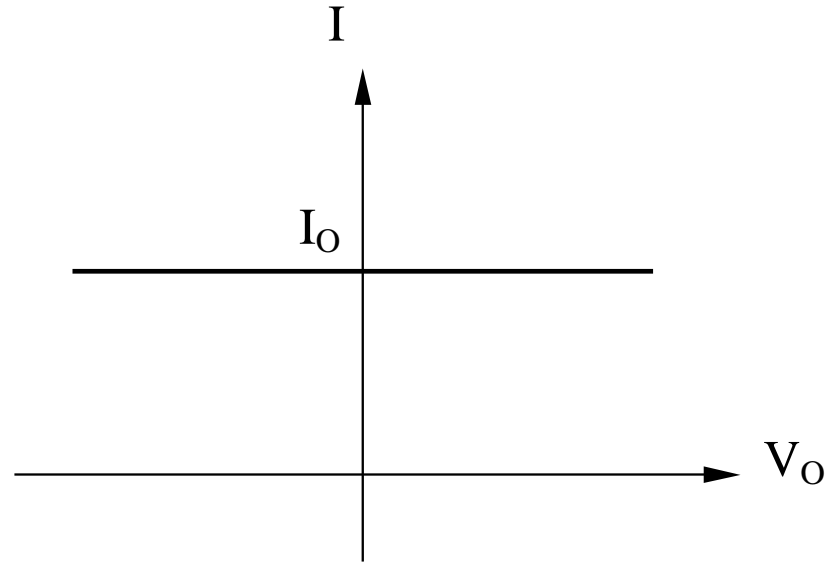
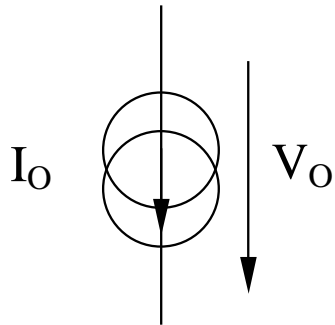

### **Parametri:**

- Curentul de iesire  $I_O$  [A]
- Rezistenta de iesire [ $\Omega$ ]

$$R_O = \left. \frac{dV_O}{dI_O} \right|_{V_{CC}, T=ct.}$$

- Tensiunea minima de iesire [V]
- Coeficientul de temperatura [A/K]

$$TC_{I_O} = \left. \frac{dI_O}{dT} \right|_{R_L, V_{CC}=ct.}$$

- Coeficientul relativ de temperatura [1/K]

$$RTC_{I_O} = \left. \frac{1}{I_O} \frac{dI_O}{dT} \right|_{R_L, V_{CC}=ct.}$$

- Factorul de rejectie al tensiunii de alimentare (Power Supply Rejection Ratio) [A/V]

$$PSRR = \left. \frac{dI_O}{dV_{CC}} \right|_{R_L, T=ct.}$$

- Sensibilitatea curentului de iesire in raport cu variatiile tensiunii de alimentare [-]

$$S_{V_{CC}}^{I_O} = \left. \frac{dI_O / I_O}{dV_{CC} / V_{CC}} \right|_{R_L, T=ct.} = \left. \frac{V_{CC}}{I_O} \frac{dI_O}{dV_{CC}} \right|_{R_L, T=ct.}$$

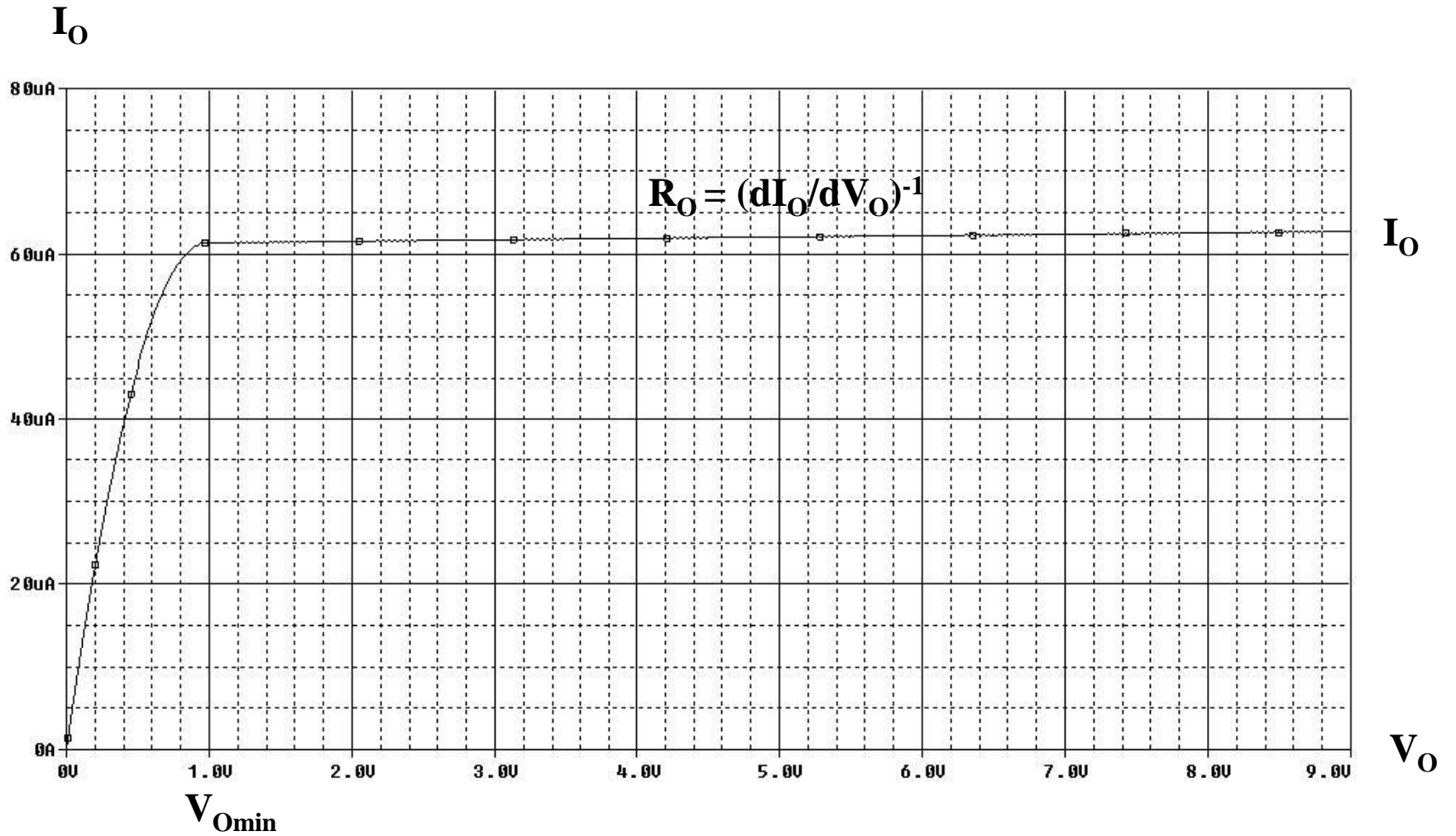

Caracteristica de iesire a unei surse de curent

# Clasificare

## I. Surse de curent elementare

- complexitate redusa
- performante modeste

## II. Surse de curent cascod

- rezistenta de iesire mare
- tensiune minima de iesire mare
- tensiune minima de alimentare mare

## III. Surse de curent cu autopolarizare

- dependenta redusa  $I_O (V_{CC})$
- necesita circuit de pornire

## IV. Surse de curent compensate cu temperatura

- dependenta redusa de temperatura
- complexitate ridicata

### **3.1.2. Surse de curent elementare**

### 3.1.2. Surse de curent elementare

#### Sursa de curent CMOS cu un tranzistor

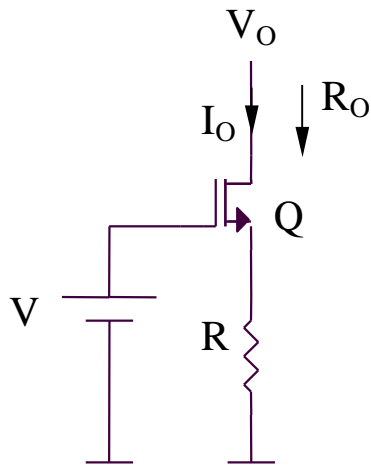

$$\left. \begin{aligned} V &= V_{GS} + I_O R \\ I_O &= \frac{K}{2} (V_{GS} - V_T)^2 \end{aligned} \right\} \Rightarrow V = V_{GS} + \frac{KR}{2} (V_{GS} - V_T)^2$$
$$\Rightarrow V_{GS} (> V_T) \Rightarrow I_O$$

$$R_O = r_{ds} (1 + g_m R)$$

$$V_{O \min} = V - V_{GS} + (V_{GS} - V_T) = V - V_T$$



## Sursa de curent bipolară cu un tranzistor

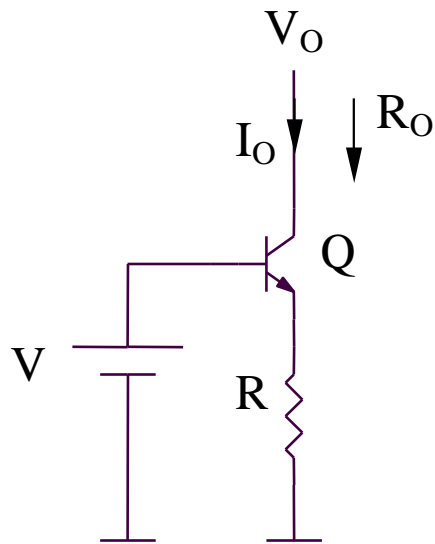

$$I_O = \frac{V - V_{BE}}{R}$$

$$R_O = r_o \left( 1 + \frac{\beta R}{r_\pi + R} \right)$$

$$V_{O \min} = V - V_{BE} + V_{CEsat}$$

$$R_O = r_o \left( 1 + \frac{\beta R_2}{r_\pi + R_1 + R_2} \right)$$

# Oglinda de curent CMOS

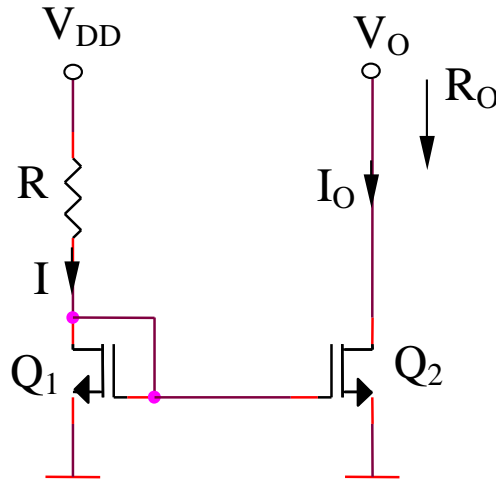

Curentul de iesire

$$\left. \begin{aligned} V_{DD} &= I_O R + V_{GS1} \\ I_O &= \frac{K}{2} (V_{GS1} - V_T)^2 \end{aligned} \right\} \Rightarrow V_{DD} = \frac{KR}{2} (V_{GS1} - V_T)^2 + V_{GS1} \Rightarrow \\
 \Rightarrow (V_{GS1})_{1,2} &= V_T - \frac{1}{KR} \pm \frac{1}{KR} \sqrt{1 + 2KR(V_{DD} - V_T)}$$

$V_{GS}$  trebuie sa fie mai mare decat  $V_T$ :

$$V_{GS1} = V_T - \frac{I}{KR} + \frac{I}{KR} \sqrt{1 + 2KR(V_{DD} - V_T)}$$

$$\Rightarrow I_O = \frac{I}{KR^2} \left[ 1 + KR(V_{DD} - V_T) - \sqrt{1 + 2KR(V_{DD} - V_T)} \right]$$

**Rezistenta de iesire**

$$R_O = r_{ds2} = \frac{1}{\lambda I_O}$$

**Tensiunea minima de iesire**

$$V_{O\min} = V_{DS2\text{sat}} = V_{GS2} - V_T = \sqrt{\frac{2I_O}{K}}$$

**Efectul de modulare a lungimii canalului**

$$\frac{I_O}{I} = \frac{\frac{K}{2}(V_{GS2} - V_T)^2 (1 + \lambda V_{DS2})}{\frac{K}{2}(V_{GS1} - V_T)^2 (1 + \lambda V_{DS1})} = \frac{1 + \lambda V_{DS2}}{1 + \lambda V_{DS1}} = \frac{1 + \lambda V_O}{1 + \lambda V_{GS1}}$$

**SIMULARI pentru oglinda de curent CMOS**  
**Caracteristica de iesire**

# SIMULARI pentru oglinda de curent CMOS

## Caracteristica de iesire

### SIM 3.1: $I_{D2}$ (V2)

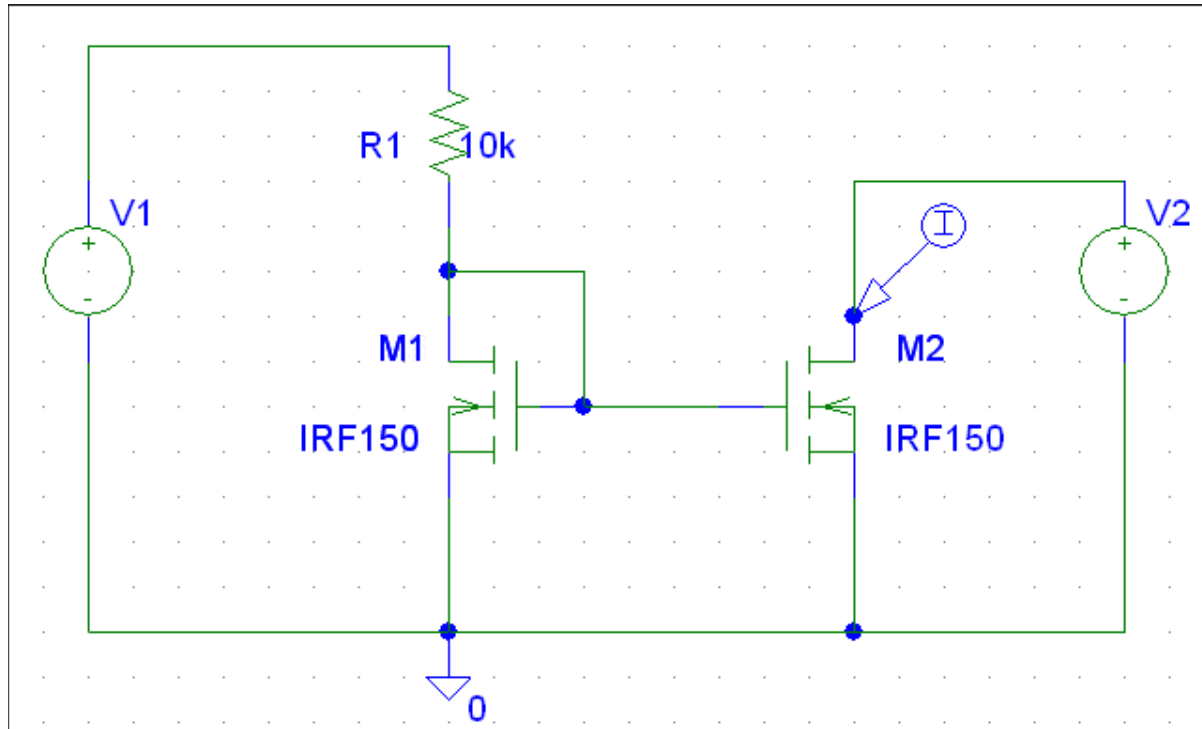

# SIMULARI pentru oglinda de curent CMOS

## Caracteristica de iesire

**SIM 3.2:**  $I_{D2}$  (V2),  $r_{ds2}$  - parametru

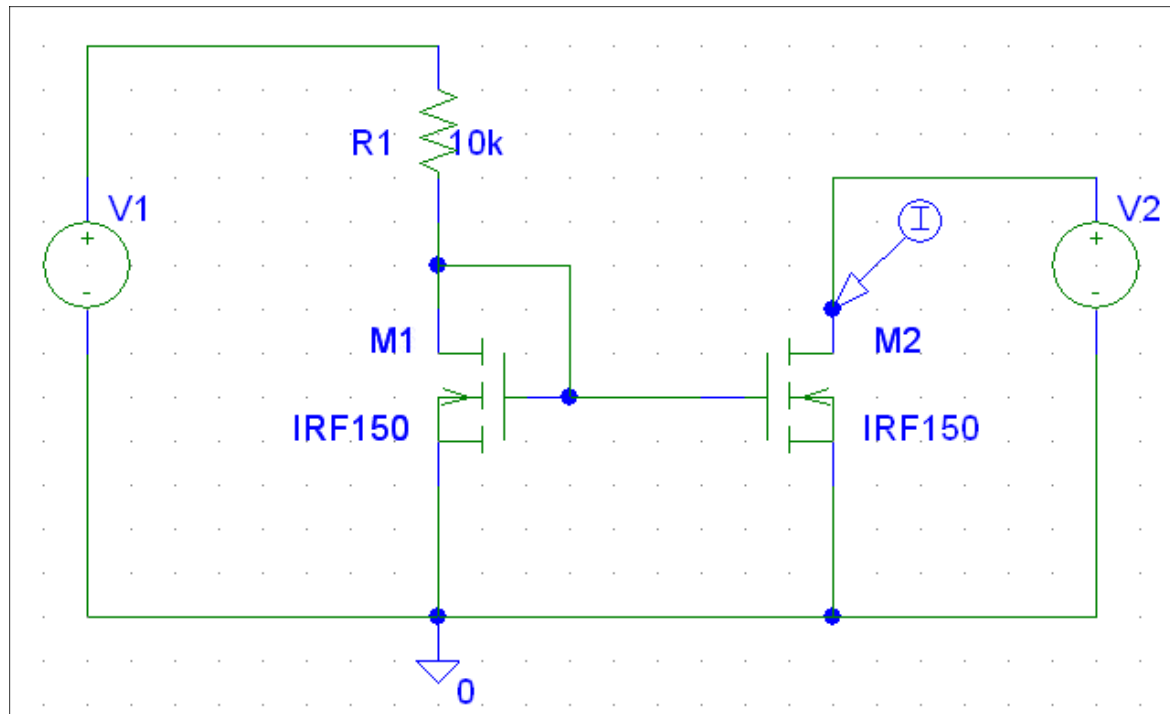

**SIMULARI pentru oglinda de curent CMOS**  
**Dependenta curentului de iesire de tensiunea de alimentare**

# SIMULARI pentru oglinda de curent CMOS

## Dependenta curentului de iesire de tensiunea de alimentare

### SIM 3.3: $I_{D2}$ (V1)

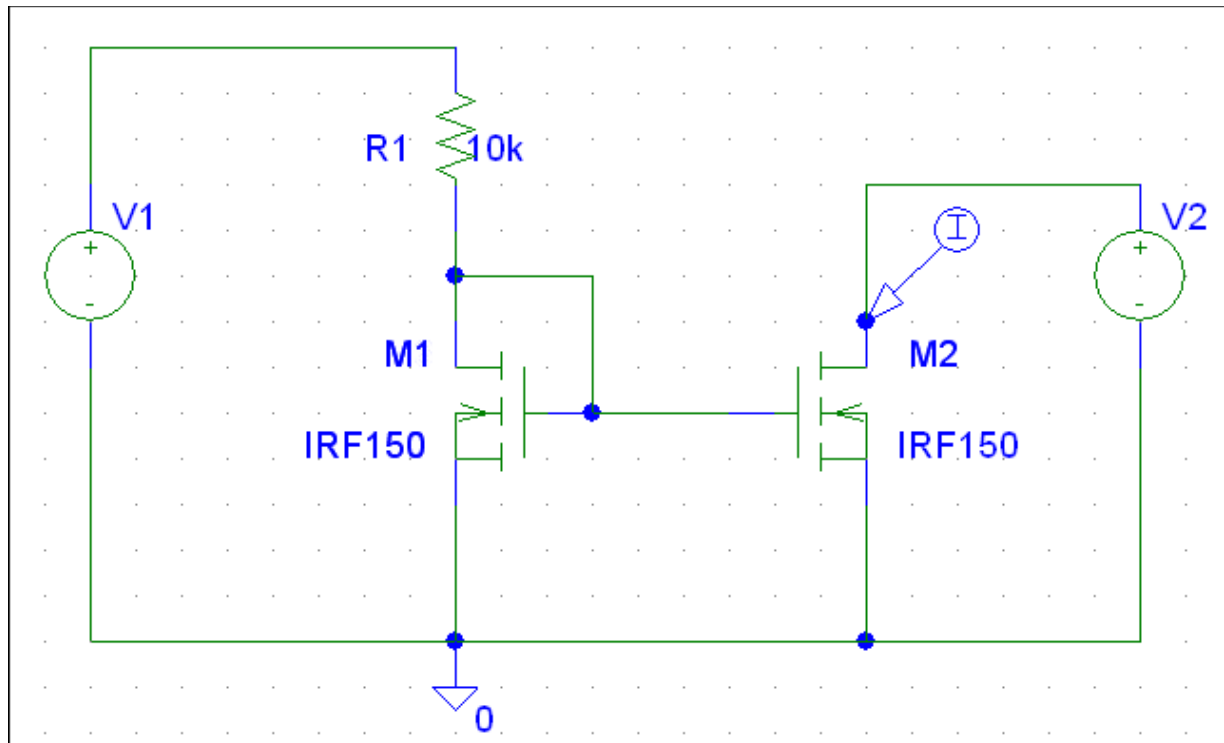



# Oglinda de curent bipolarara

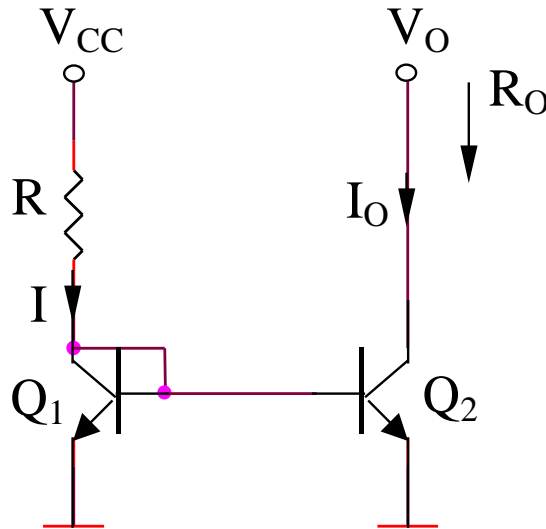

Curent de iesire

$$\left. \begin{aligned} I &= \frac{V_{CC} - V_{BE}}{R} \cong I_{S1} \exp\left(\frac{V_{BE1}}{V_{th}}\right) \\ I_O &\cong I_{S2} \exp\left(\frac{V_{BE2}}{V_{th}}\right) \\ V_{BE1} &= V_{BE2} \end{aligned} \right\} \Rightarrow \frac{I_O}{I} \cong \frac{I_{S2}}{I_{S1}} \Rightarrow I_O \cong \frac{V_{CC} - V_{BE}}{R} \frac{I_{S2}}{I_{S1}}$$

## Rezistența de iesire

$$R_O = r_o = \frac{V_A}{I_{C2}} = \frac{V_A}{I_O}$$

## Tensiune minima de iesire

$$V_{O\min} = V_{CE2\text{sat.}}$$

## Efect Early

$$I = \frac{V_{CC} - V_{BE}}{R} = I_{S1} \exp\left(\frac{V_{BE1}}{V_{th}}\right) \left(1 + \frac{V_{CE1}}{V_A}\right)$$

$$I_O = I_{S2} \exp\left(\frac{V_{BE2}}{V_{th}}\right) \left(1 + \frac{V_{CE2}}{V_A}\right)$$

$$\frac{I_O}{I} = \frac{I_{S2}}{I_{S1}} \frac{1 + \frac{V_{CE2}}{V_A}}{1 + \frac{V_{CE1}}{V_A}} = \frac{I_{S2}}{I_{S1}} \frac{1 + \frac{V_O}{V_A}}{1 + \frac{V_{BE1}}{V_A}}$$

## Influenta $\beta$

$$\frac{I_O}{I} = \frac{\beta I_B}{\beta I_B + 2I_B} = \frac{\beta}{\beta + 2}$$

**SIMULARI pentru oglinda de curent bipolară**  
**Caracteristica de ieșire**

# SIMULARI pentru oglinda de curent bipolara

## Caracteristica de iesire

### SIM 3.4: $I_{C1}$ (V2)

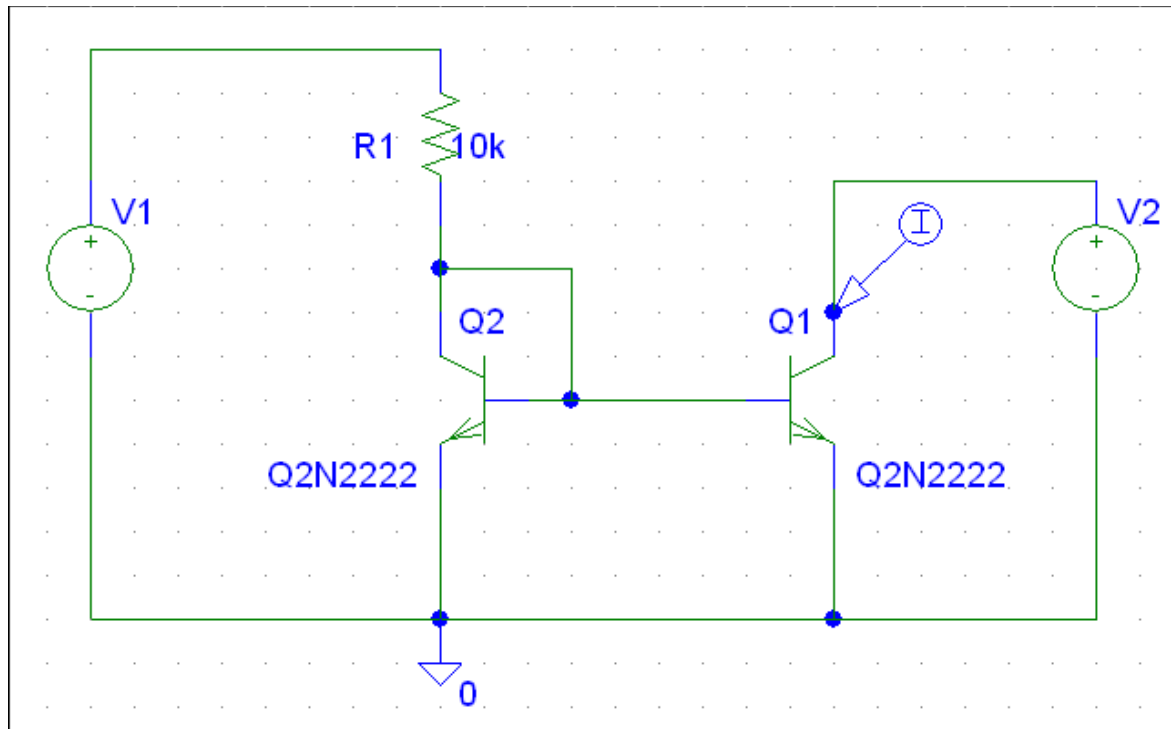

# SIMULARI pentru oglinda de curent bipolara

## Caracteristica de iesire

SIM 3.5:  $I_{C1}$  (V2),  $V_{A1}$  - parametru

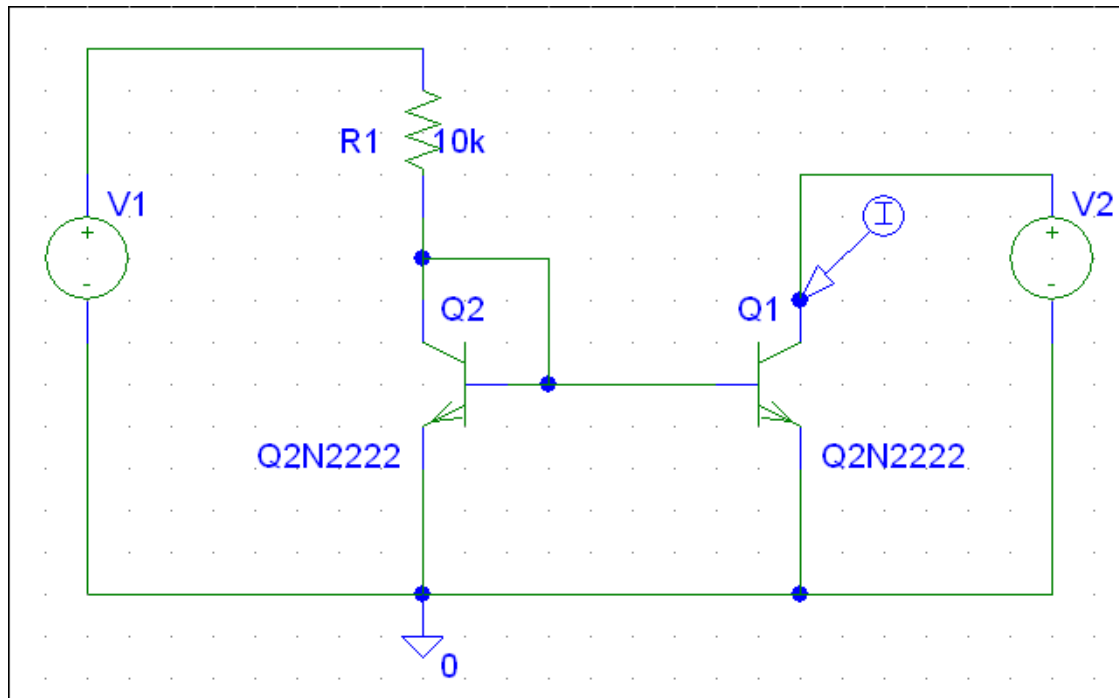

**SIMULARI pentru oglinda de curent bipolară**  
**Dependenta curentului de iesire de tensiunea de alimentare**

# SIMULARI pentru oglinda de curent bipolară

## Dependenta curentului de iesire de tensiunea de alimentare

### SIM 3.6: $I_{C1}$ (V1)

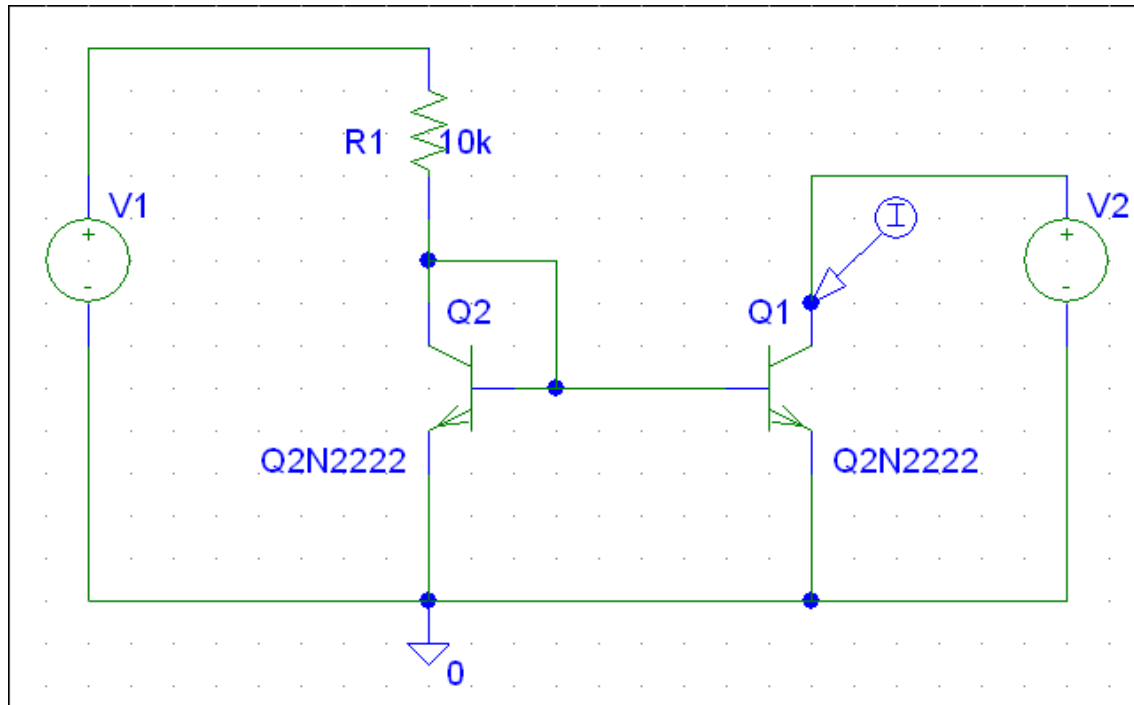

# Sursa de curent cu reducerea efectului $\beta$

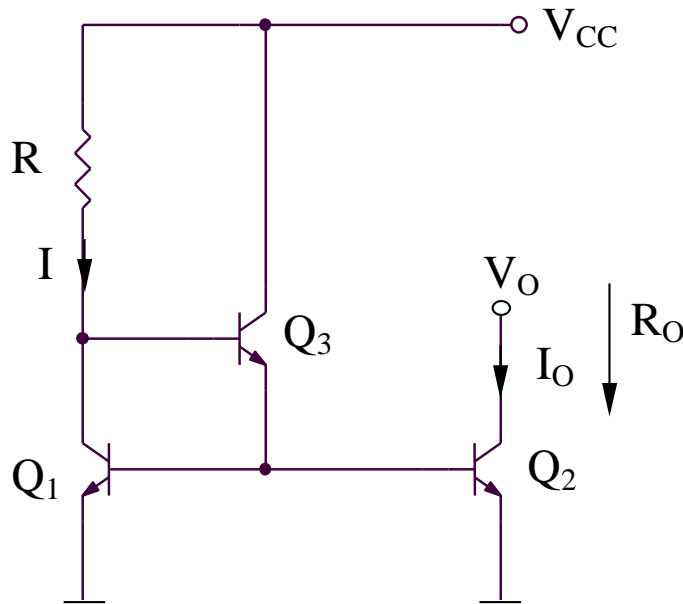

**Curent de iesire**

$$I_O \cong I = \frac{V_{CC} - 2V_{BE}}{R}$$

**Rezistenta de iesire**

$$R_O = r_o = \frac{V_A}{I_{C2}} = \frac{V_A}{I_O}$$

**Tensiune minima de iesire**

$$V_{O\min} = V_{CE2\text{sat.}}$$

**Influenta  $\beta$**

$$\frac{I_O}{I} = \frac{\beta I_B}{\beta I_B + \frac{2I_B}{\beta + 1}} = \frac{1}{1 + \frac{2}{\beta^2 + \beta}} \cong 1$$



# Sursa de curent multipla

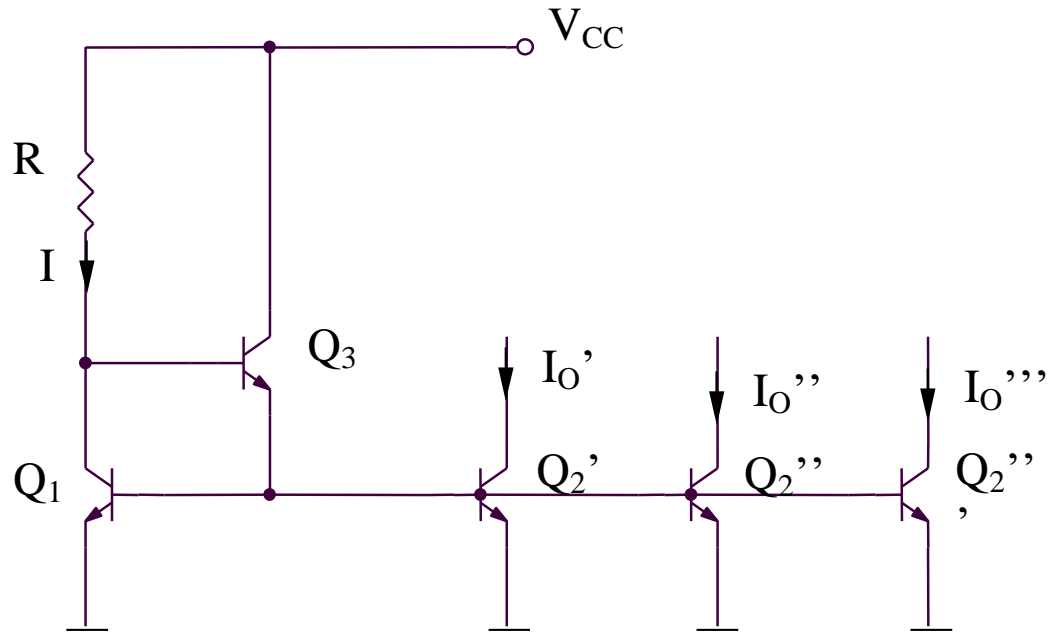

# Sursa de curent Widlar bipolarara

## Curentul de iesire

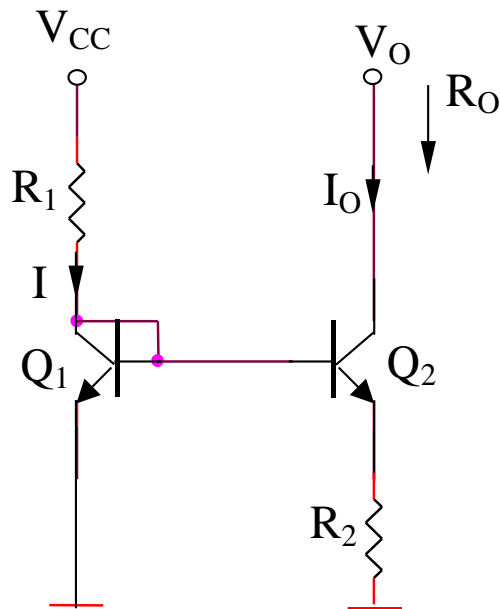

$$I = \frac{V_{CC} - V_{BE}}{R_1}$$

$$I_O = \frac{V_{BE1} - V_{BE2}}{R_2} = \frac{V_{th} \ln\left(\frac{I}{I_S}\right) - V_{th} \ln\left(\frac{I_O}{I_S}\right)}{R_2}$$

$$I_O = \frac{V_{th}}{R_2} \ln\left(\frac{I}{I_O}\right) = \frac{V_{th}}{R_2} \ln\left(\frac{V_{CC} - V_{BE}}{R_1 I_O}\right)$$

## Tensiunea minima de iesire

$$V_{O \min} = V_{CE2 \text{ sat.}} + I_O R_2$$

## Rezistenta de iesire

$$R_O = r_o \left( 1 + \frac{\beta R_2}{r_{\pi 2} + R_2 + (1/g_{m1}) // R_1} \right) = \frac{V_A}{I_O} \left( 1 + \frac{\beta R_2}{r_{\pi 2} + R_2 + (1/g_{m1}) // R_1} \right)$$

## PSRR

$$\frac{dI_O}{dV_{CC}} = \frac{d}{dV_{CC}} \left[ \frac{V_{th}}{R_2} \ln \left( \frac{V_{CC} - V_{BE}}{R_1 I_O} \right) \right]$$

$$\frac{dI_O}{dV_{CC}} = \frac{V_{th}}{R_2} \frac{R_1 I_O}{V_{CC} - V_{BE}} \frac{R_1 I_O - (V_{CC} - V_{BE}) R_1 \frac{dI_O}{dV_{CC}}}{(R_1 I_O)^2}$$

$$\frac{dI_O}{dV_{CC}} = \frac{1}{R_2} \frac{V_{th}}{V_{CC} - V_{BE}} \frac{1}{1 + \frac{V_{th}}{R_2 I_O}}$$

**Sensibilitatea curentului de iesire in raport cu variatiile tensiunii de alimentare**

$$S_{V_{CC}}^{I_O} = \frac{V_{CC}}{I_O} \frac{dI_O}{dV_{CC}} = \frac{1}{1 + \frac{R_2 I_O}{V_{th}}} = \frac{1}{1 + \ln \left( \frac{V_{CC} - V_{BE}}{R_1 I_O} \right)}$$

## Curentul de iesire

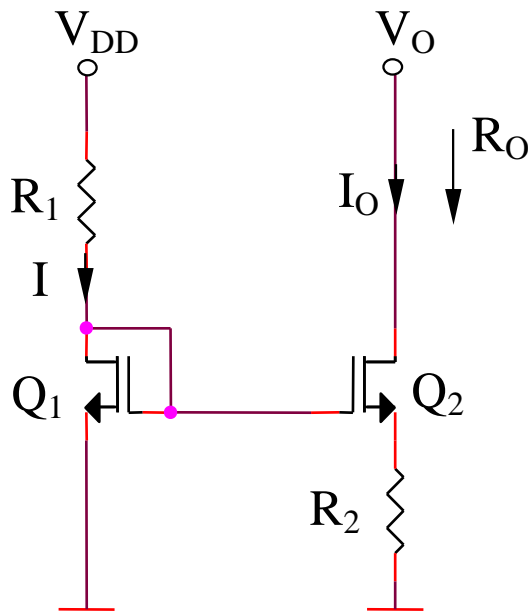

$$V_{GS1} = V_T - \frac{I}{KR_1} + \frac{I}{KR_1} \sqrt{1 + 2KR_1 (V_{DD} - V_T)}$$

$$V_{GS1} = V_{GS2} + I_O R_2 = V_{GS2} + \frac{KR_2}{2} (V_{GS2} - V_T)^2$$

$$(V_{GS2} > V_T)$$

$$I_O = \frac{K}{2} (V_{GS2} - V_T)^2 (1 + \lambda V_{DS2})$$

## Tensiunea minima de iesire

$$V_{O\min} = V_{DS2\text{sat}} + I_O R_2 = \sqrt{\frac{2I_O}{K}} + I_O R_2$$

## Rezistenta de iesire

$$R_O = r_{ds2} (1 + g_{m2} R_2)$$

# Sursa de curent standard

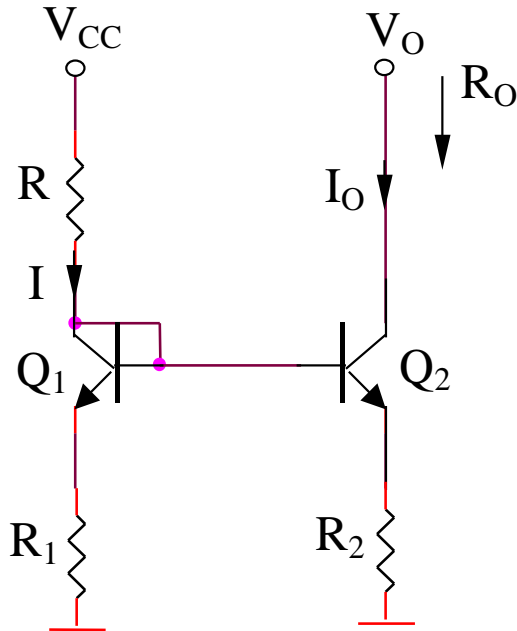

## Rezistenta de iesire

$$R_O = r_{o2} \left( 1 + \frac{\beta R_2}{R_2 + r_{\pi 2} + R // (1 / g_{m1} + R_1)} \right)$$

## Curentul de iesire

$$v_{BE1} + R_1 I = v_{BE2} + R_2 I_O$$

$$I_O = \frac{I}{R_2} (R_1 I + v_{BE1} - v_{BE2})$$

$$\frac{I_O}{I} = \frac{R_1}{R_2} + \frac{V_{th}}{R_2 I} \ln \left( \frac{I}{I_O} \frac{I_{S2}}{I_{S1}} \right)$$

Se poate determina  $I/I_O$  deoarece:

$$I = \frac{V_{CC} - v_{BE}}{R + R_1}$$

Daca  $R_1 I \gg v_{BE1} - v_{BE2}$ :

$$\frac{I_O}{I} = \frac{R_1}{R_2}$$

## Sursa de curent standard cu iesire multipla

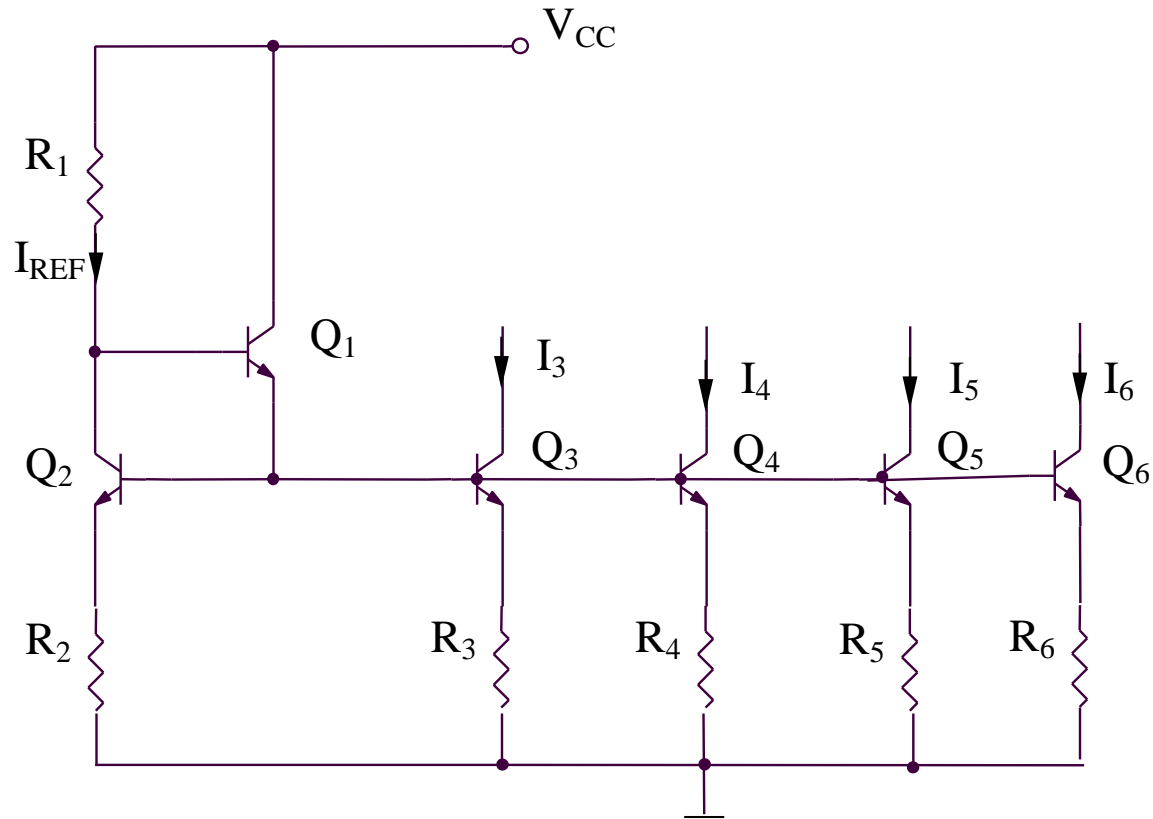

Daca ariile tranzistoarelor sunt alese in asa fel incat densitatile de curent sa fie egale, atunci tensiunile baza-emitor vor fi egale.

$$v_{BE2} - v_{BE3} = V_{th} \ln\left(\frac{I_{REF} I_{S3}}{I_3 I_{S2}}\right) = V_{th} \ln\left(\frac{jA_2 A_3}{jA_3 A_2}\right) = 0$$

Deci:

$$v_{BE2} = \dots = v_{BE6}$$

si:

$$I_3 R_3 = I_4 R_4 = I_5 R_5 = I_6 R_6 = I_{REF} R_2$$

Cei patru curenti de iesire au expresiile:

$$I_3 = I_{REF} \frac{R_2}{R_3}; \dots; I_6 = I_{REF} \frac{R_2}{R_6}$$

unde:

$$I_{REF} = \frac{V_{CC} - 2v_{BE}}{R_1 + R_2}$$

# Sursa de curent utilizand ca referinta tensiunea baza-emitor

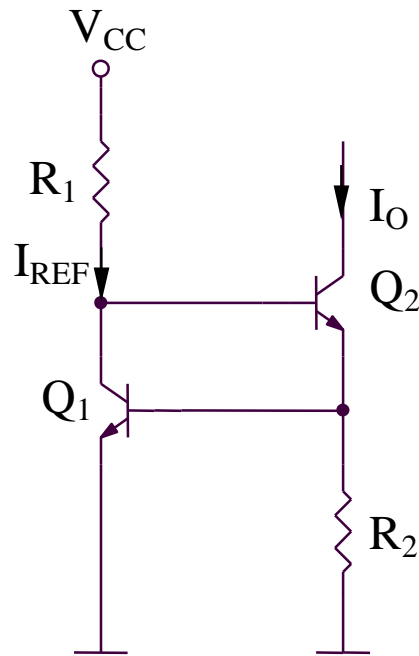

$$I_O = \frac{v_{BE1}}{R_2} = \frac{V_{th}}{R_2} \ln \frac{V_{CC} - 2v_{BE}}{R_1 I_S}$$



### **3.1.3. Surse de curent cascod**

### 3.1.3. Surse de curent cascod

#### Sursa de curent cascod CMOS (1)

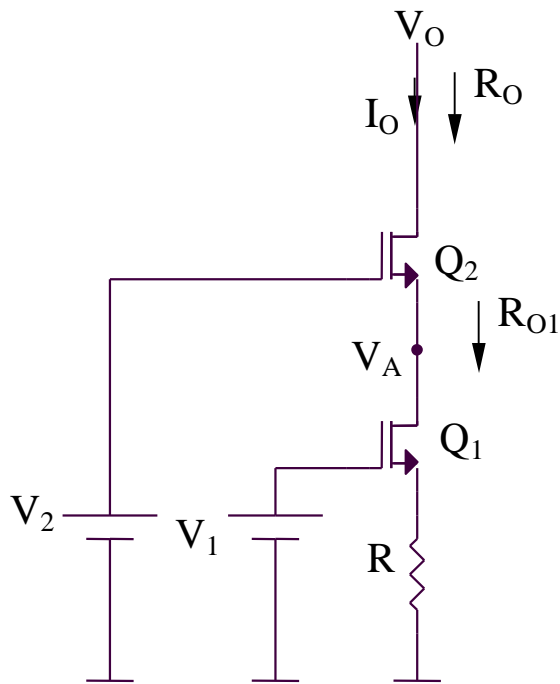

Curentul de iesire

$$\left. \begin{aligned} V_1 &= V_{GS1} + I_O R \\ I_O &= \frac{K}{2} (V_{GS1} - V_T)^2 \end{aligned} \right\} \Rightarrow V_1 = V_{GS1} + \frac{KR}{2} (V_{GS1} - V_T)^2$$

$$\Rightarrow V_{GS1} (> V_T) \Rightarrow I_O$$

Rezistenta de iesire

$$R_O = r_{ds2} (1 + g_m R_{O1}) \cong g_m^2 r_{ds}^2 R$$

$$R_{O1} = r_{ds1} (1 + g_m R)$$

Tensiunea minima de iesire

$$V_{Omin} = V_2 - V_{GS2} + (V_{GS2} - V_T) = V_2 - V_T$$

Este necesar ca:

$$V_{DS1} > V_{DS1sat} \Leftrightarrow$$

$$\Leftrightarrow (V_2 - V_{GS2}) - (V_1 - V_{GS1}) > V_{DS1sat} \Leftrightarrow$$

$$\Leftrightarrow V_2 - V_1 > V_{DS1sat} = V_{GS} - V_T = \sqrt{\frac{2I_O}{K}}$$

# Oglinda de curent cascod CMOS (2)

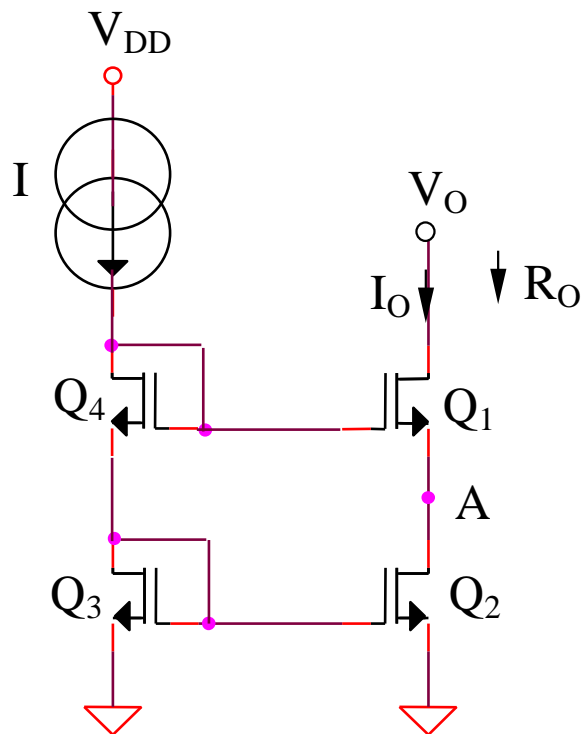

Curentul de iesire

$$\frac{I_O}{I} = \frac{1 + \lambda V_{DS2}}{1 + \lambda V_{DS3}}$$

Rezistenta de iesire

$$R_O = r_{ds1} (1 + g_{m1} r_{ds2}) \cong g_{m1} r_{ds2}^2$$

Tensiunea minima de iesire

$$V_{O\min} = V_A + V_{DS1\text{sat}} = V_{GS} + (V_{GS} - V_T)$$

$$V_{O\min} = 2V_{GS} - V_T \cong V_T + 2\sqrt{\frac{2I}{K}}$$

**SIMULARI pentru oglinda de curent CMOS cascod**  
**Caracteristica de iesire**

# SIMULARI pentru oglinda de curent CMOS cascod

## Caracteristica de iesire

SIM 3.7:  $I_{D2}$  (V2)

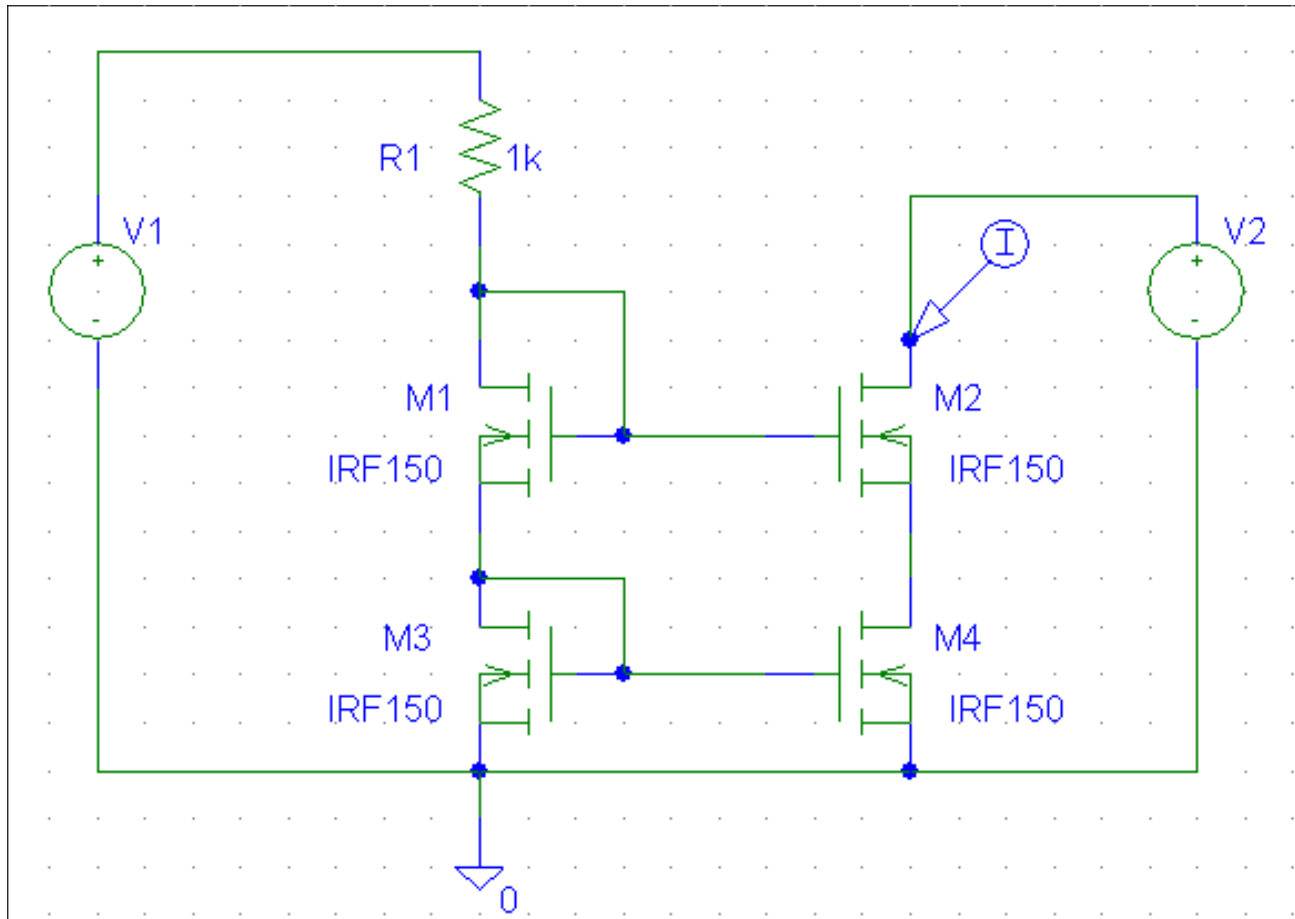

# SIMULARI pentru oglinda de curent CMOS cascod

## Caracteristica de iesire

**SIM 3.8:  $I_{D2}$  (V2),  $r_{ds2}$ ,  $r_{ds4}$  - parametri**

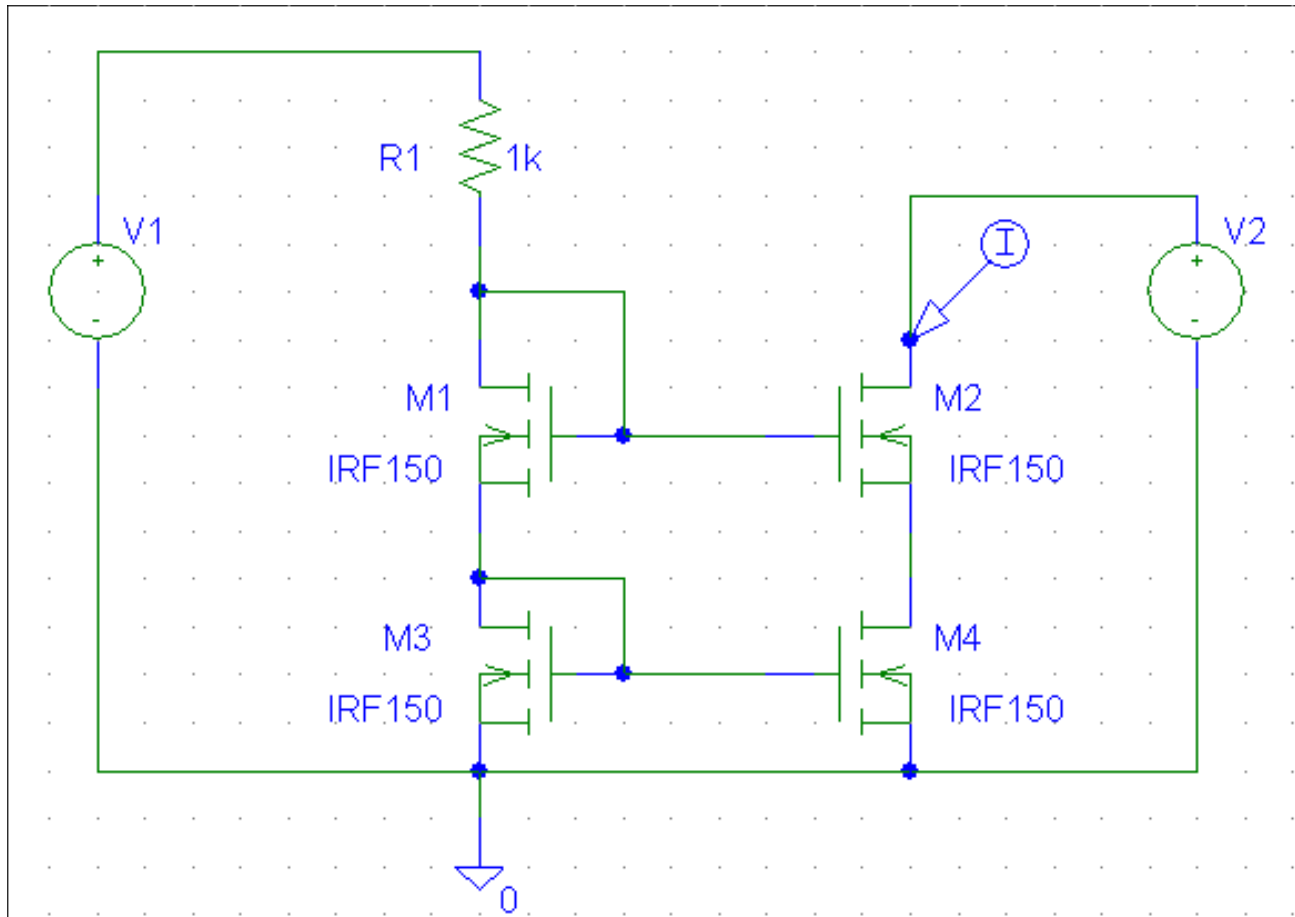

**SIMULARI pentru oglinda de curent CMOS cascod**  
**Dependenta curentului de iesire de tensiunea de alimentare**

# SIMULARI pentru oglinda de curent CMOS cascod Dependenta curentului de iesire de tensiunea de alimentare

## SIM 3.9: $I_{D2}$ (V1)

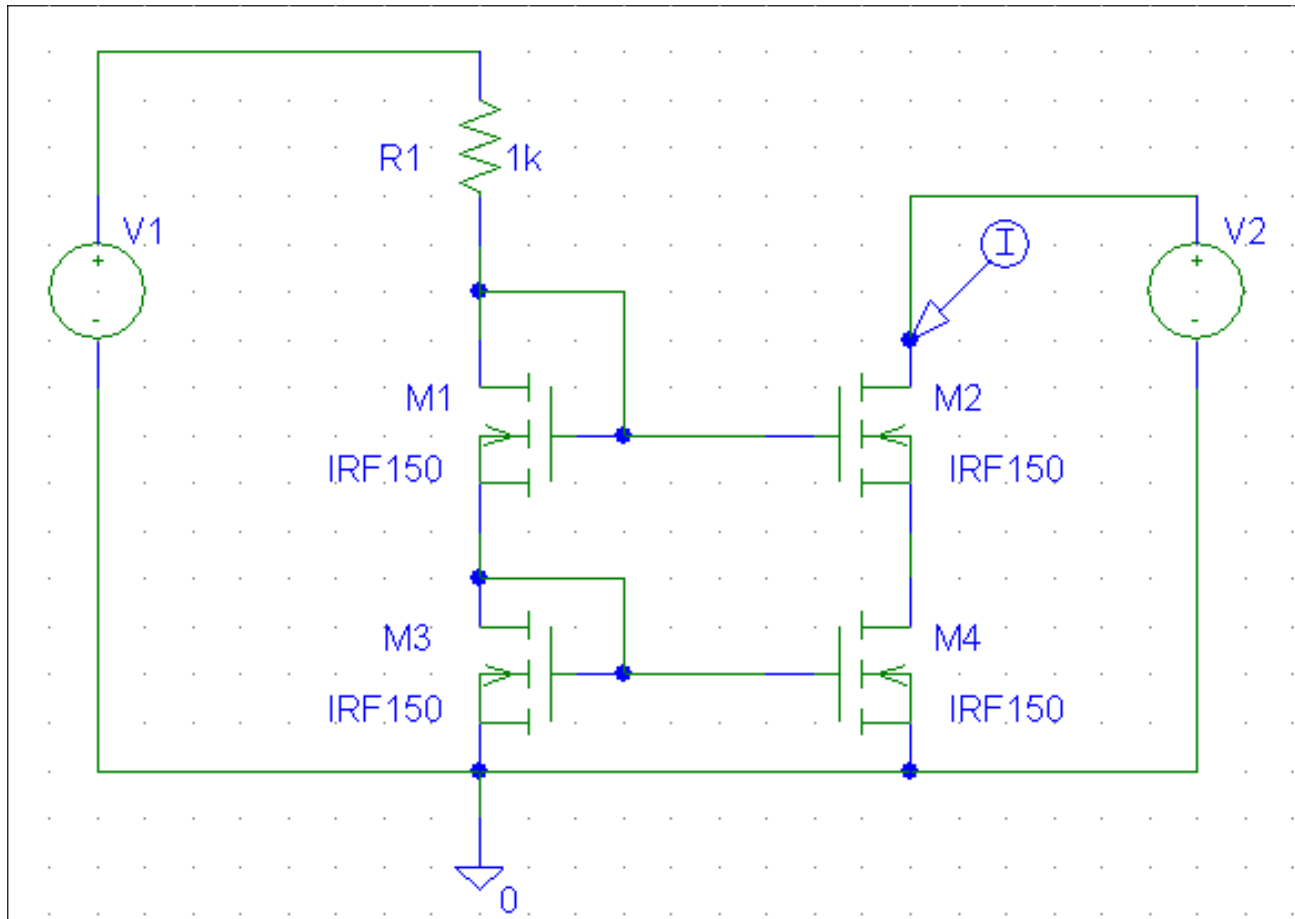



# Sursa de curent cascod bipolară (1)

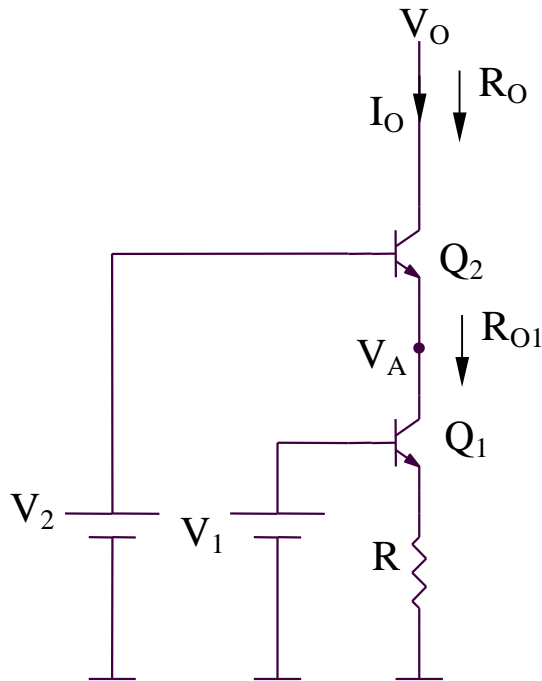

**Curentul de iesire**

$$I_O = \frac{V_1 - V_{BE1}}{R}$$

**Rezistenta de iesire**

$$R_O = r_{o2} \left( 1 + \frac{\beta R_{O1}}{r_{\pi 2} + R_{O1}} \right) \cong \beta r_{o2}$$

$$R_{O1} = r_{o1} \left( 1 + \frac{\beta R}{r_{\pi 1} + R} \right) \gg r_{\pi 2}$$

**Tensiune minima de iesire**

$$V_{O \min} = V_A + V_{CE2 \text{ sat}} = V_2 - V_{BE2} + V_{CE2 \text{ sat}}$$

Este necesar ca:

$$V_{CE1} > V_{CE1 \text{ sat}} \Leftrightarrow$$

$$\Leftrightarrow (V_2 - V_{BE2}) - (V_1 - V_{BE1}) > V_{CE1 \text{ sat}} \Leftrightarrow$$

$$\Leftrightarrow V_2 - V_1 > V_{CE1 \text{ sat}}$$

## Oglinda de curent cascod bipolară (2)

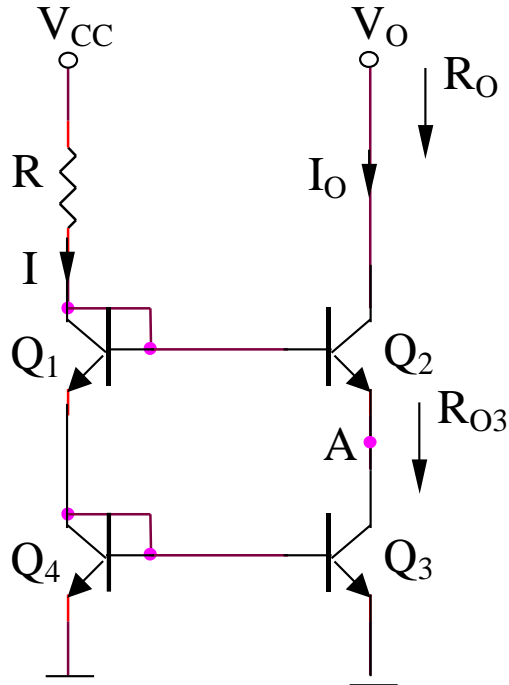

Curentul de iesire

$$I_O = I = \frac{V_{CC} - 2v_{BE}}{R}$$

Rezistenta de iesire

$$R_O = r_{o2} \left( 1 + \beta \frac{R_{O3}}{r_{\pi 2} + R_{O3} + R // (2 / g_{m1})} \right)$$

$$R_{O3} = r_{o3} \gg r_{\pi 2}, R // (2 / g_{m1})$$

Deci:

$$R_O \cong \beta r_{o2}$$

Tensiunea minima de iesire

$$V_{O \min} = V_A + V_{CE2 \text{ sat}}$$

$$V_A = v_{BE1} + v_{BE4} - v_{BE2} = v_{BE}$$

## Sursa de curent cascod bipolară (3)

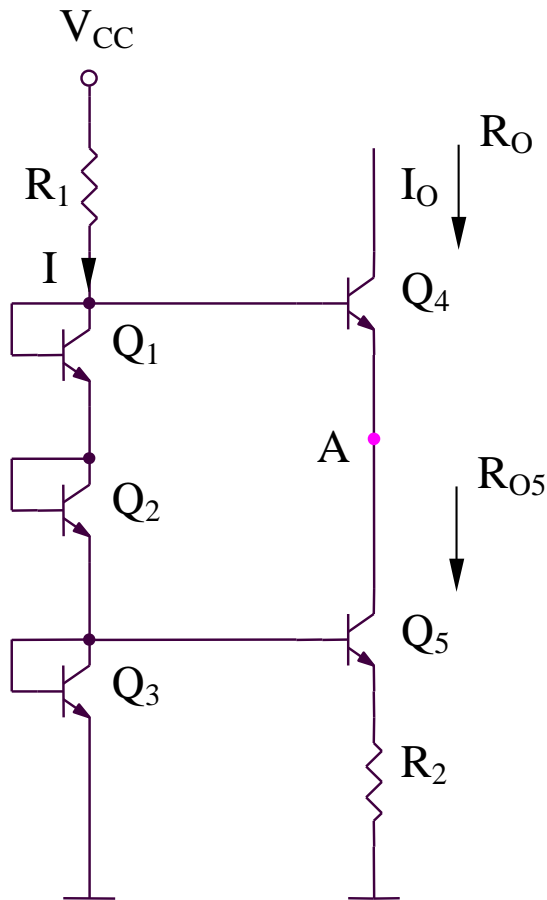

Curentul de iesire

S

$$I_O = \frac{v_{BE3} - v_{BE5}}{R_2} = \frac{V_{th}}{R_2} \ln\left(\frac{I}{I_O}\right)$$

$$I = \frac{V_{CC} - 3v_{BE}}{R_1}$$

Rezistenta de iesire

$$R_O = r_{o4} \left( 1 + \beta \frac{R_{O5}}{r_{\pi4} + R_{O5} + R_1 // (3 / g_{m1})} \right)$$

$$R_{O5} \cong r_{o5} \left( 1 + \frac{\beta R_2}{r_{\pi5} + R_2 + 1 / g_{m3}} \right)$$

$$R_{O5} \gg r_{\pi4}, R_1 // (3 / g_{m1})$$

Deci:

$$R_O \cong \beta r_{o4}$$

Tensiunea minima de iesire

$$V_{Omin} = V_A + V_{CE4sat}$$

$$V_A = 2v_{BE}$$

# Sursa de curent cascod MOS (3)

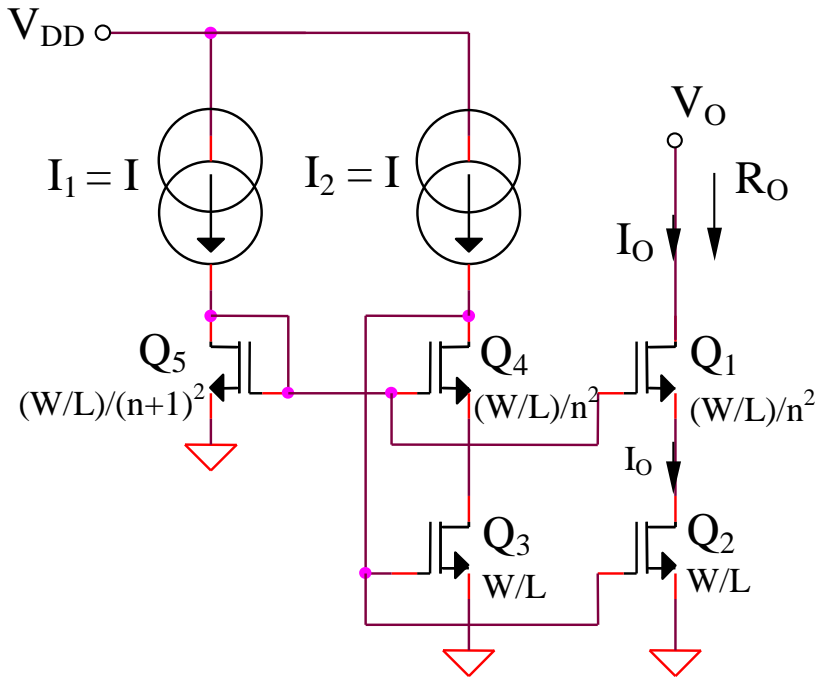

## Curentul de iesire

$$I_O = I$$

## Rezistenta de iesire

$$R_O = r_{ds1} (1 + g_{m1} r_{ds2}) \cong g_{m1} r_{ds2}^2$$

## Tensiunea minima de iesire

$$\left. \begin{aligned} I &= \frac{K'}{2} \frac{W/L}{(n+1)^2} (V_{GS5} - V_T)^2 \\ I &= \frac{K'}{2} \frac{W/L}{n^2} (V_{GS1(4)} - V_T)^2 \\ I &= \frac{K'}{2} (W/L) (V_{GS2(3)} - V_T)^2 \end{aligned} \right\} \Rightarrow$$

$$\Rightarrow \begin{cases} V_{GS5} - V_T = (n+1)(V_{GS2(3)} - V_T) \\ V_{GS1(4)} - V_T = n(V_{GS2(3)} - V_T) \end{cases}$$

Tensiunea drena-sursa a tranzistorului  $Q_2$  este:

$$V_{DS2} = V_{GS5} - V_{GS1} = (V_{GS5} - V_T) - (V_{GS1} - V_T) = V_{GS2} - V_T = V_{DS2sat}$$

Deci,  $Q_2$  este polarizat la limita de saturatie. Rezulta:

$$V_{Omin} = V_{DS1sat} + V_{DS2} = (n+1)(V_{GS2} - V_T) = (n+1)\sqrt{\frac{2I}{K}}$$

### **3.1.4. Surse de curent cu autopolarizare**

### 3.1.4. Surse de curent cu autopolarizare

#### Oglinda de curent

$$I_O = \frac{V_{CC} - v_{BE}}{R}$$

$$S_{V_{CC}}^{I_O} = \frac{V_{CC}}{I_O} \frac{\partial I_O}{\partial V_{CC}} \cong 1$$

#### Sursa de curent Widlar bipolară

$$I_O = \frac{V_{th}}{R_2} \ln \frac{I}{I_O}$$

$$\frac{\partial I_O}{\partial V_{CC}} = \frac{V_{th}}{R_2} \frac{I_O}{I} \left( \frac{1}{I_O} \frac{\partial I}{\partial V_{CC}} - \frac{I}{I_O^2} \frac{\partial I_O}{\partial V_{CC}} \right)$$

$$\frac{\partial I_O}{\partial V_{CC}} = \frac{\frac{V_{th}}{IR_2}}{1 + \frac{V_{th}}{R_2 I_O}} \frac{\partial I}{\partial V_{CC}}$$

$$S_{V_{CC}}^{I_O} = \frac{V_{CC}}{I_O} \frac{\partial I_O}{\partial V_{CC}} = \frac{V_{CC}}{I} \frac{1}{1 + \frac{R_2 I_O}{V_{th}}} \frac{\partial I}{\partial V_{CC}} \cong \frac{1}{1 + \frac{R_2 I_O}{V_{th}}}$$

## Sursa de curent utilizand ca referinta tensiunea baza-emitor

$$I_O = \frac{V_{th}}{R_2} \ln \frac{V_{CC} - 2v_{BE}}{R_1 I_S}$$

$$\frac{\partial I_O}{\partial V_{CC}} \cong \frac{V_{th}}{R_2} \frac{R_1 I_S}{V_{CC} - 2v_{BE}} \frac{1}{R_1 I_S}$$

$$S_{V_{CC}}^{I_O} \cong \frac{V_{th}}{v_{BE}} \cong 4\%$$



# Sursa de curent cu autopolarizare utilizand ca referinta tensiunea baza-emitor

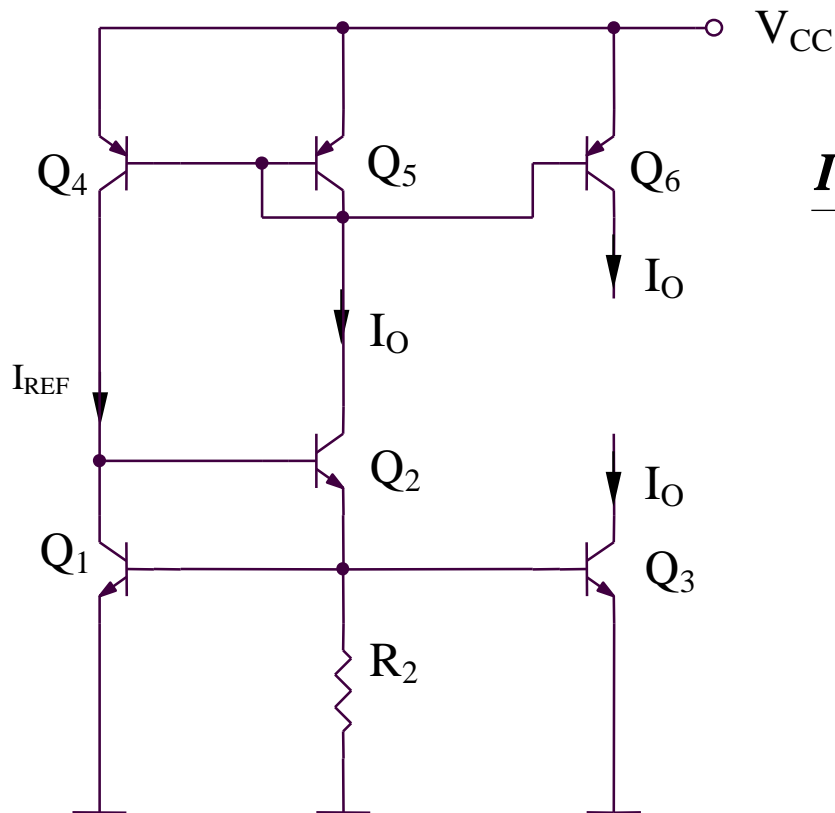

$$I_O = \frac{v_{BE1}}{R_2} = \frac{V_{th}}{R_2} \ln \frac{I_{REF}}{I_S}$$

$$\frac{I_{REF}}{I_O} = \frac{1 + \frac{V_{CC} - 2v_{BE}}{V_A}}{1 + \frac{v_{BE}}{V_A}} \cong 1 + \frac{V_{CC} - 2v_{BE}}{V_A}$$

$$\Rightarrow I_O = \frac{V_{th}}{R_2} \ln \frac{I_O}{I_S} + \frac{V_{th}}{R_2} \ln \left( 1 + \frac{V_{CC} - 2v_{BE}}{V_A} \right)$$

Derivand:

$$\frac{\partial I_O}{\partial V_{CC}} = \frac{V_{th}}{R_2 (V_A + V_{CC})}$$

rezulta:

$$S_{V_{CC}}^{I_O} \cong \frac{V_{th}}{v_{BE}} \frac{I}{1 + \frac{V_A}{V_{CC}}}$$

# Sursa de curent Widlar cu autopolarizare

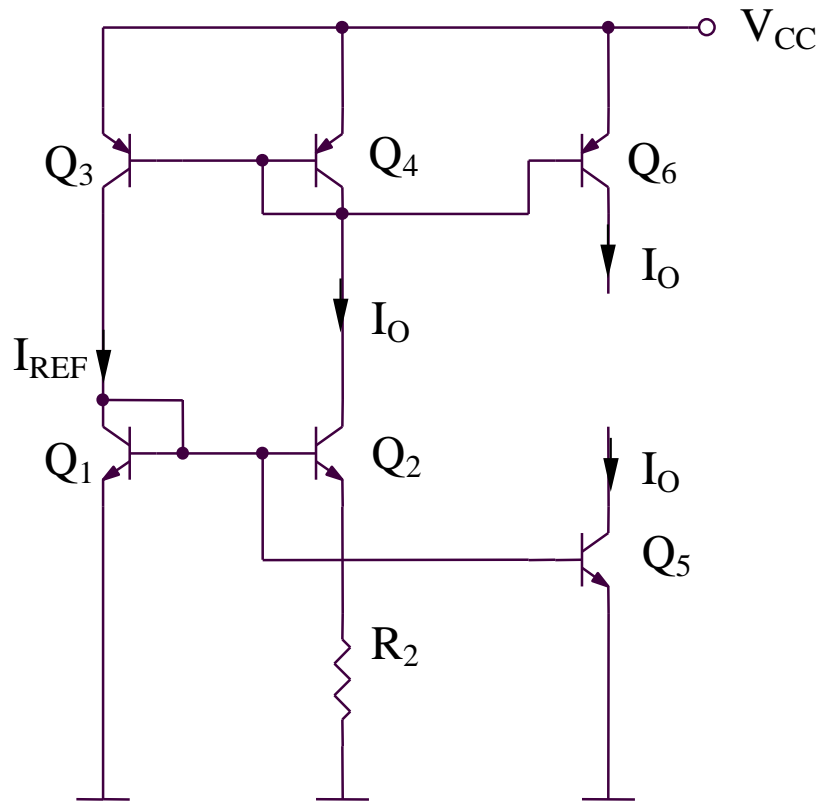

$$I_O = \frac{v_{BE1} - v_{BE2}}{R_2}$$

$$I_O = \frac{V_{th}}{R_2} \ln\left(\frac{I_{REF}}{I_O}\right) + \frac{V_{th}}{R_2} \ln\left(\frac{I_{S2}}{I_{S1}}\right)$$

$$I_O \cong \frac{V_{th}}{R_2} \ln\left(1 + \frac{V_{CC}}{V_A}\right) + \frac{V_{th}}{R_2} \ln\left(\frac{I_{S2}}{I_{S1}}\right)$$

$$S_{V_{CC}}^{I_O} \cong \frac{V_{CC}}{V_A} \frac{1}{\ln\left(\frac{I_{S2}}{I_{S1}}\right)}$$

# Sursa de curent CMOS cu autopolarizare (1)

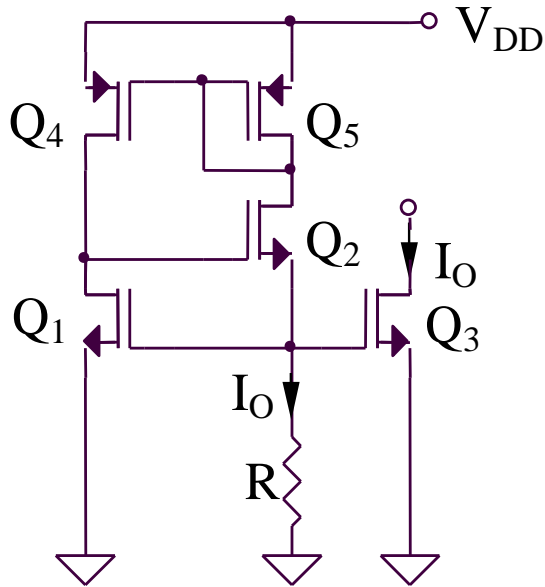

Curentul de iesire

$$I_O = \frac{V_{GS}}{R} = \frac{K}{2} (V_{GS} - V_T)^2$$

$$\frac{KR}{2} V_{GS}^2 - (1 + KR V_T) V_{GS} + \frac{KR}{2} V_T^2 = 0$$

Rezolvand ecuatia pentru  $V_{GS}$  rezulta:

$$V_{GS1,2} = V_T + \frac{1}{KR} \pm \frac{\sqrt{2KR V_T + 1}}{KR}$$

$$V_{GS} = V_T + \frac{1}{KR} + \frac{\sqrt{2KR V_T + 1}}{KR}$$

Deci:

$$I_O = \frac{1}{KR^2} \left( 1 + KR V_T + \sqrt{1 + 2KR V_T} \right)$$

## Sursa de curent CMOS cu autopolarizare (2)

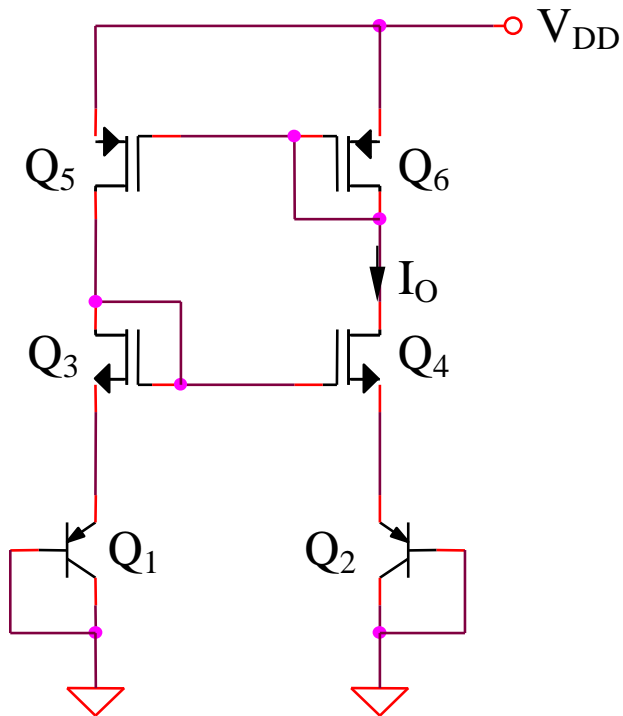

Curentul de iesire

$$V_T + \sqrt{\frac{2I_O}{4K}} + V_{th} \ln\left(\frac{I_O}{I_S}\right) =$$

$$= V_T + \sqrt{\frac{2I_O}{K}} + V_{th} \ln\left(\frac{I_O}{10I_S}\right)$$

Rezulta:

$$I_O = 2K[V_{th} \ln(10)]^2$$

$$V_{th} = \frac{kT}{q} \text{ - tensiunea termica}$$

## Sursa de curent CMOS cu autopolarizare (3)

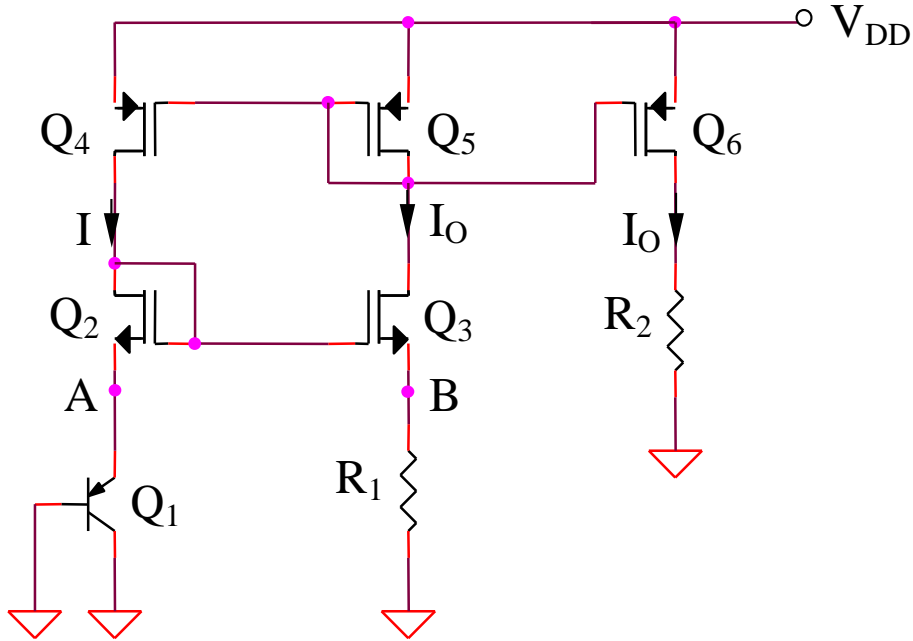

### Curentul de iesire

Pentru tranzistoare MOS identice,  
 $V_A = V_B$ , deci:

$$I_O = \frac{V_{EB1}}{R_1}$$

**SIMULARI pentru sursa de curent CMOS cu autopolarizare (3)**  
**Dependenta curentului de iesire de tensiunea de alimentare**

# SIMULARI pentru sursa de curent CMOS cu autopolarizare (3)

## Dependenta curentului de iesire de tensiunea de alimentare

### SIM 3.10: $I_{D2}$ (V1)

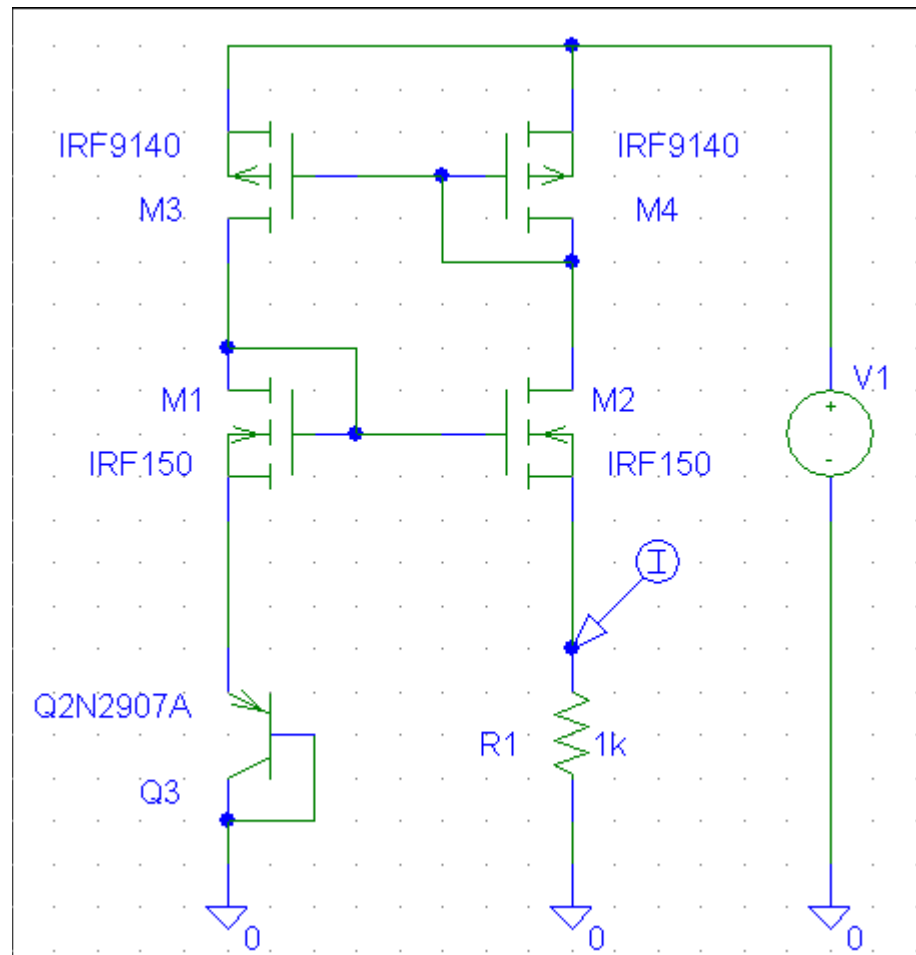

**SIMULARI pentru sursa de curent CMOS cu autopolarizare (3)**  
**Dependenta curentului de iesire de temperatura**



# SIMULARI pentru sursa de curent CMOS cu autopolarizare (3)

## Dependenta curentului de iesire de temperatura

SIM 3.11:  $I_{D2}$  (t)

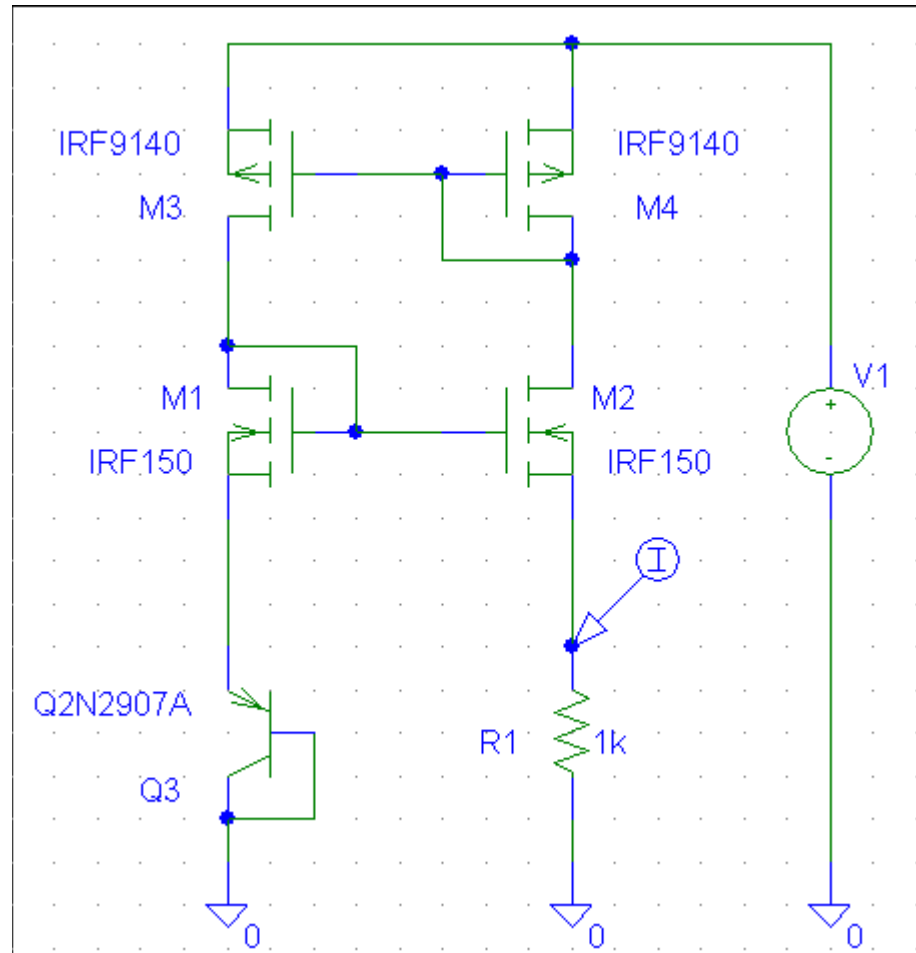

# Sursa de curent CMOS cu autopolarizare (4)

S

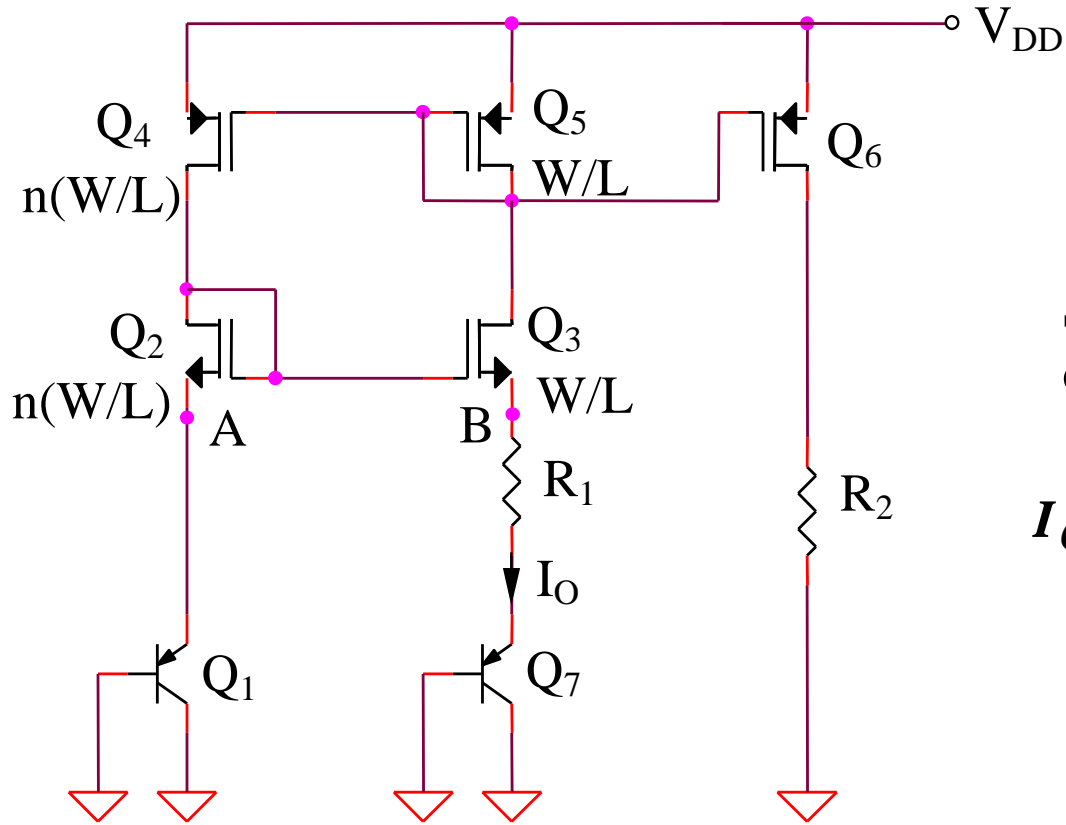

## Curentul de iesire

Se poate demonstra ca  $V_A = V_B$ ,  
deci:

$$I_O = \frac{|V_{BE1}| - |V_{BE7}|}{R_1} = \frac{V_{th}}{R_1} \ln(n)$$

# Sursa de curent CMOS cu autopolarizare (5)

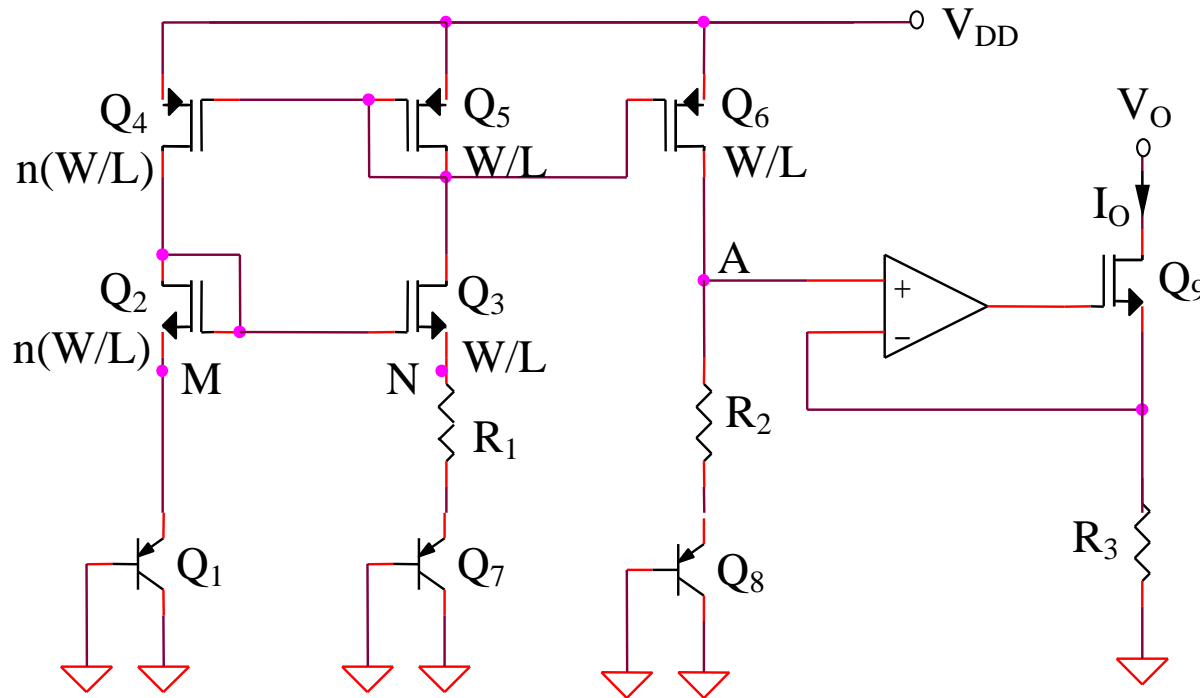

$$\left. \begin{aligned}
 V_{GS2} &= V_{GS3} \\
 V_{R2} &= R_2 \frac{V_{EB1} - V_{EB7}}{R_1} = \frac{R_2}{R_1} V_{th} \ln(n)
 \end{aligned} \right\} \Rightarrow I_O(T) = \frac{I}{R_3} \left[ \frac{R_2}{R_1} V_{th} \ln(n) + V_{EB8}(T) \right]$$

$$V_{EB}(T) = A + BT + CT \ln\left(\frac{T}{T_0}\right)$$

## Sursa de curent CMOS cu autopolarizare (5) – cont.

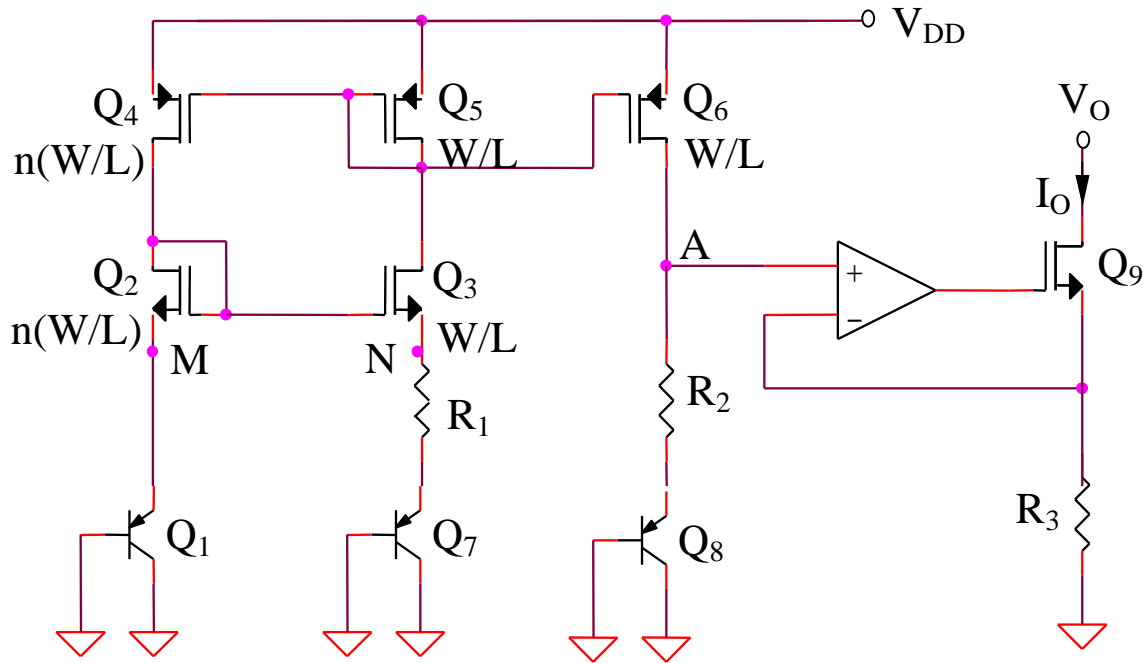

$$\Rightarrow I_O(T) = \frac{I}{R_3} \left[ \frac{R_2}{R_1} \frac{kT}{q} \ln(n) + A + BT + CT \ln\left(\frac{T}{T_0}\right) \right]$$

Conditia de corectie liniara a caracteristicii poate fi scrisa astfel:

$$B + \frac{R_2}{R_1} \frac{k}{q} \ln(n) = 0$$

Rezulta:

$$I_O(T) = \frac{I}{R_3} \left[ A + CT \ln\left(\frac{T}{T_0}\right) \right]$$

## **3.2. Surse de tensiune**

## 3.2. Surse de tensiune

### 3.2.1. Clasificare

#### I. Surse de tensiune elementare

- complexitate redusa
- performante modeste

#### II. Surse de tensiune cu reactie

- rezistenta de iesire redusa
- complexitate medie

#### III. Surse de tensiune compensate cu temperatura

- dependenta redusa de temperatura a tensiunii de iesire
- complexitate ridicata

### **3.2.2. Surse de tensiune cu reactie**

## 3.2.2. Surse de tensiune cu reactie

### Surse de tensiune cu stabilizare serie (schema bloc)

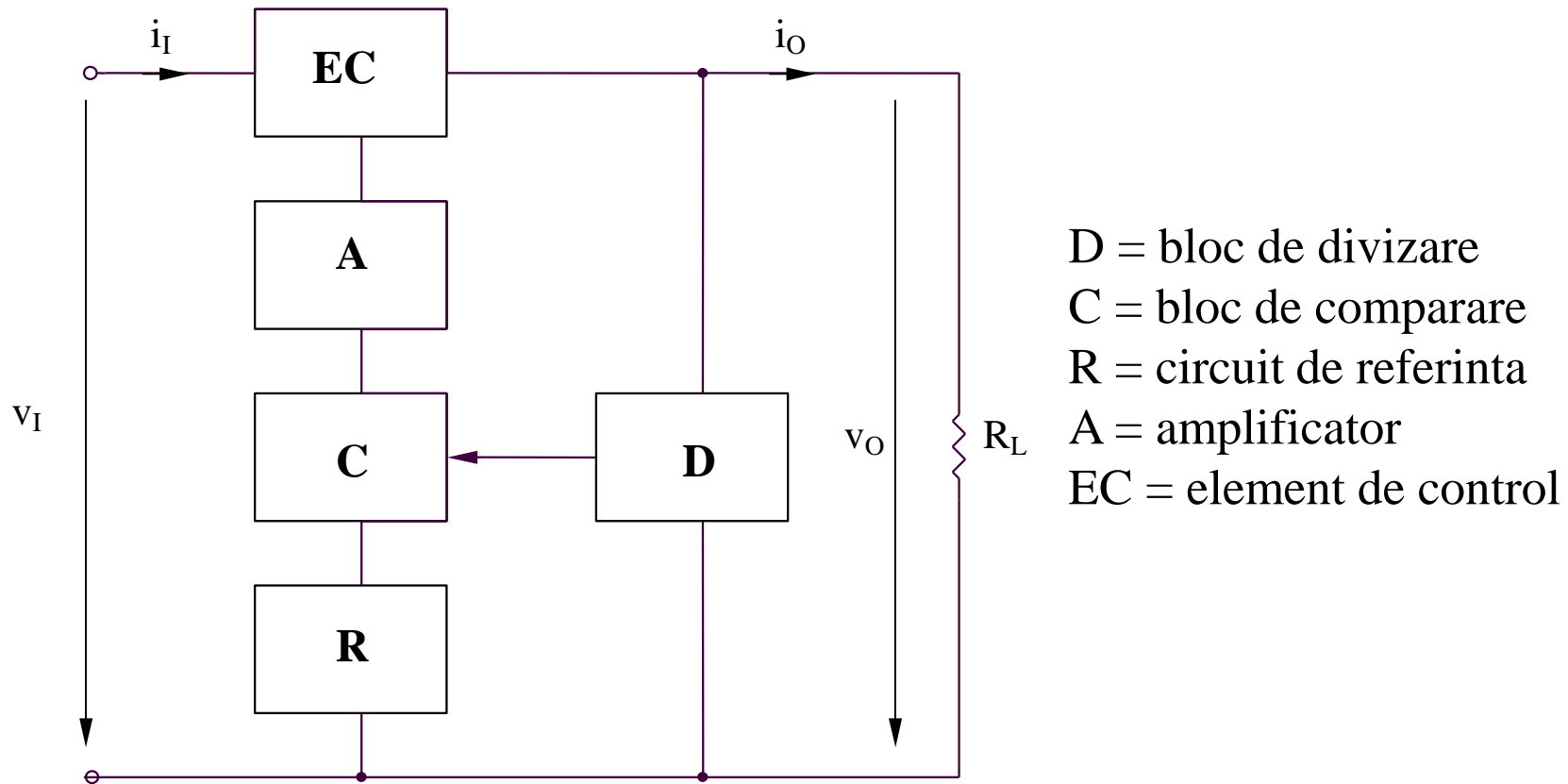



## Surse de tensiune cu stabilizare paralel (schema bloc)

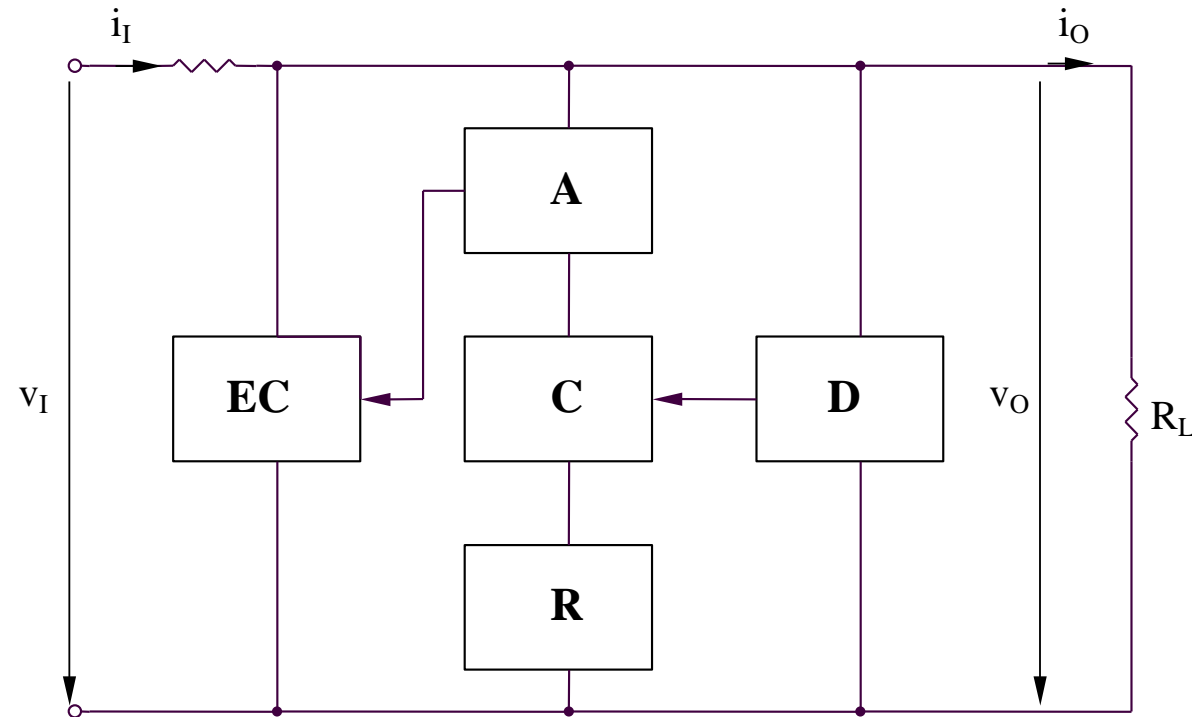

D = bloc de divizare

C = bloc de comparare

R = circuit de referinta

A = amplificator

EC = element de control

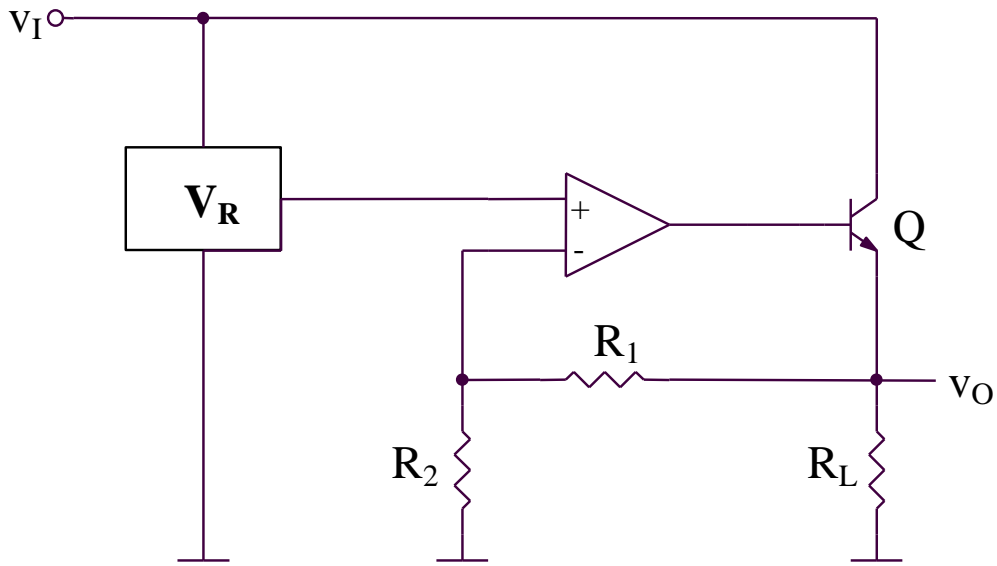

$$V_R = V_O \frac{R_2}{R_1 + R_2}$$

$$V_O = V_R \left( 1 + \frac{R_1}{R_2} \right)$$

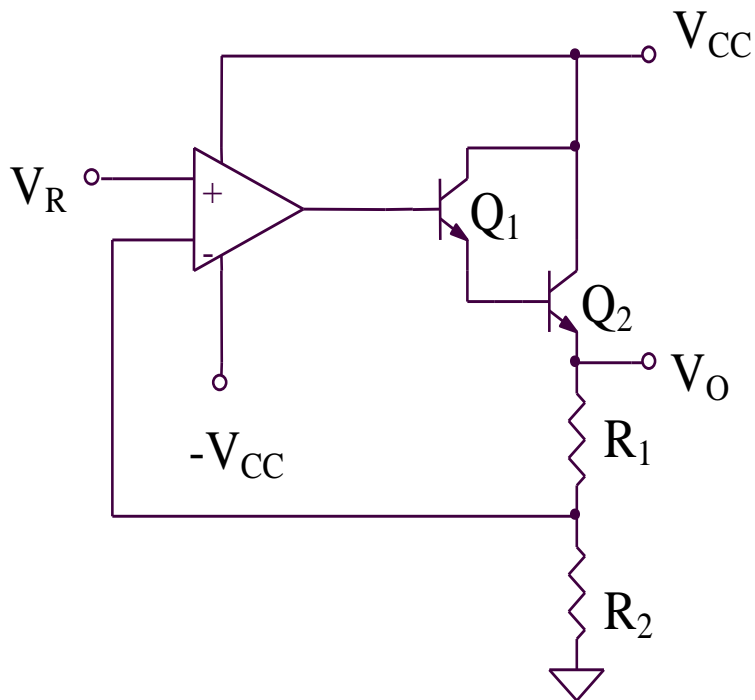

$$V_R = V_O \frac{R_2}{R_1 + R_2}$$

$$V_O = V_R \left( 1 + \frac{R_1}{R_2} \right)$$

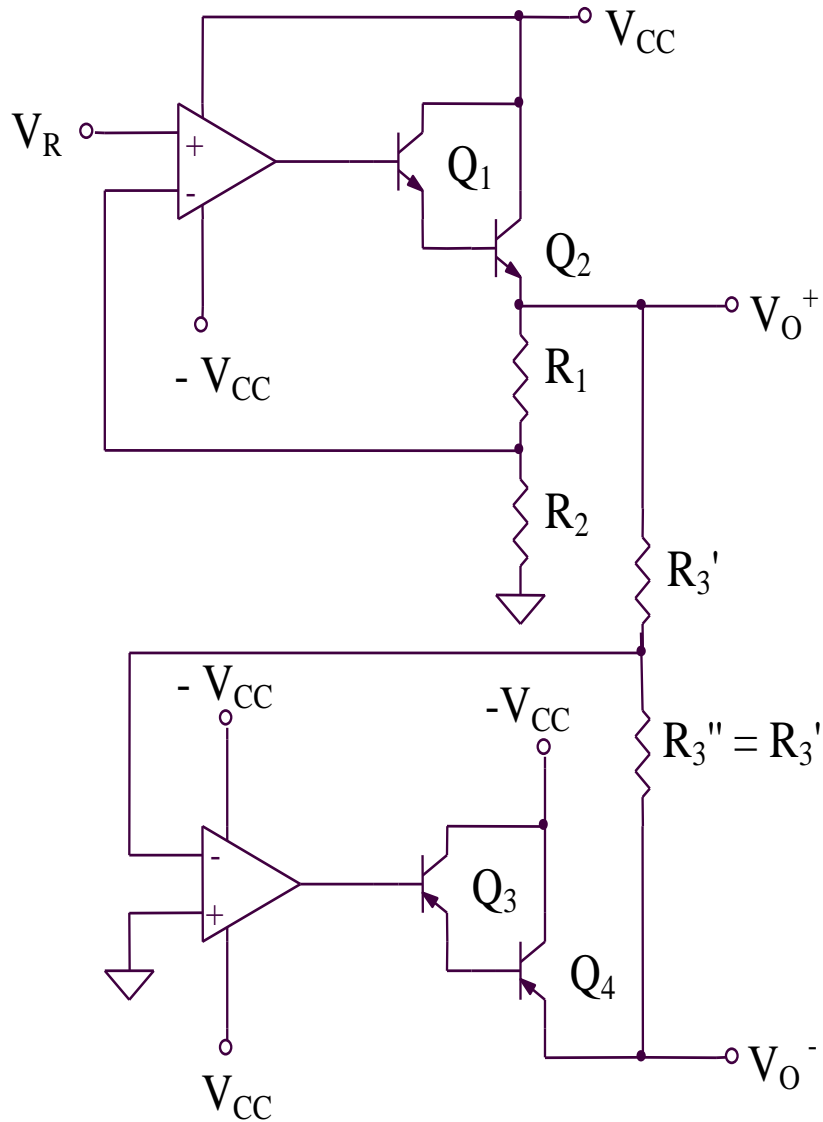

$$V_R = V_O^+ \frac{R_2}{R_1 + R_2}$$

$$V_O^+ = V_R \left( 1 + \frac{R_1}{R_2} \right)$$

$$\frac{V_O^+}{R_3'} = -\frac{V_O^-}{R_3''} \Rightarrow V_O^- = -V_O^+$$

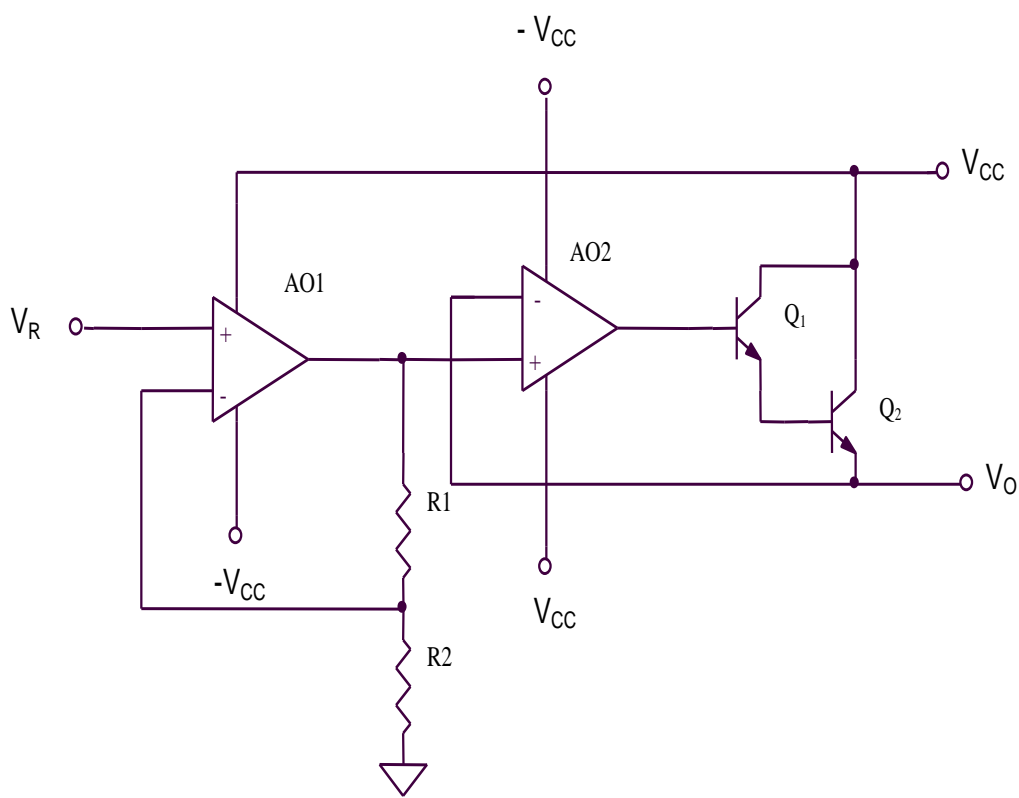

$$V_R = V_O \frac{R_2}{R_1 + R_2}$$

$$V_O = V_R \left( 1 + \frac{R_1}{R_2} \right)$$

## Protectia la suprasarcina (1)

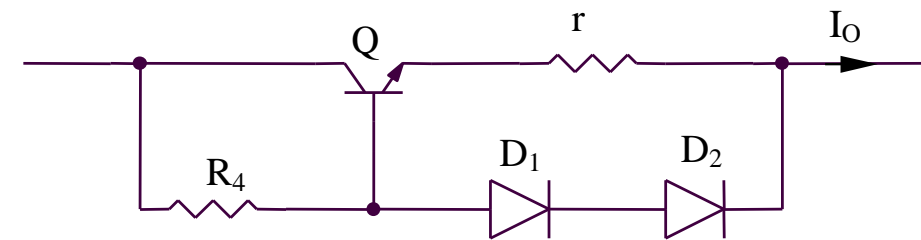

$$I_{OL} = \frac{V_{D1} + V_{D2} - V_{BE}}{r} \cong \frac{V_D}{r}$$

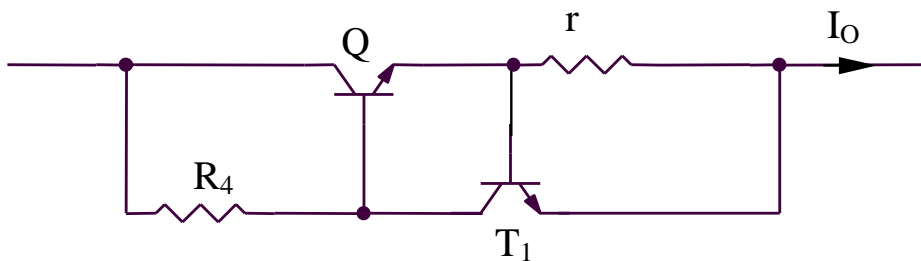

$$I_{OL} = \frac{V_{BE}}{r}$$

## Protectia la suprasarcina (2)

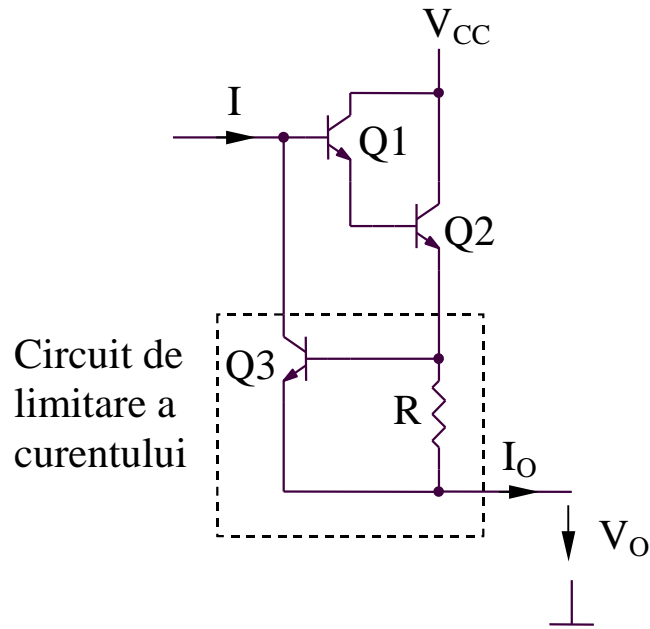

$$I_{OL} = \frac{V_{BE3}}{R}$$

# circuitul BA 723

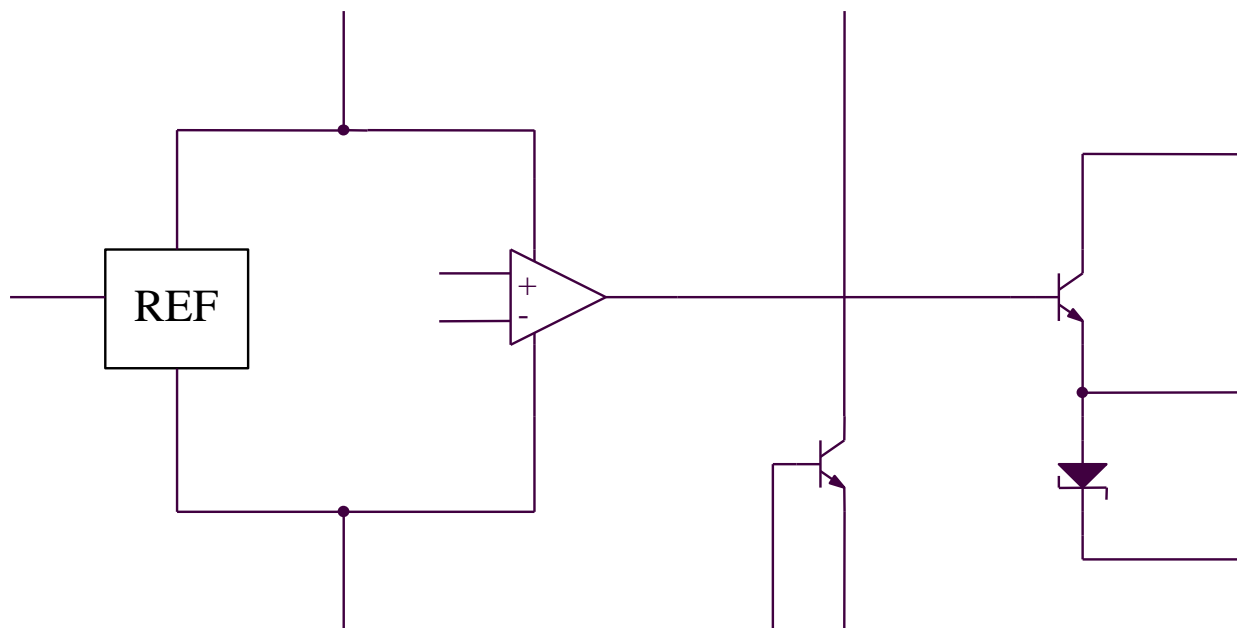

## Sursa de tensiune pentru $V_O < V_R$

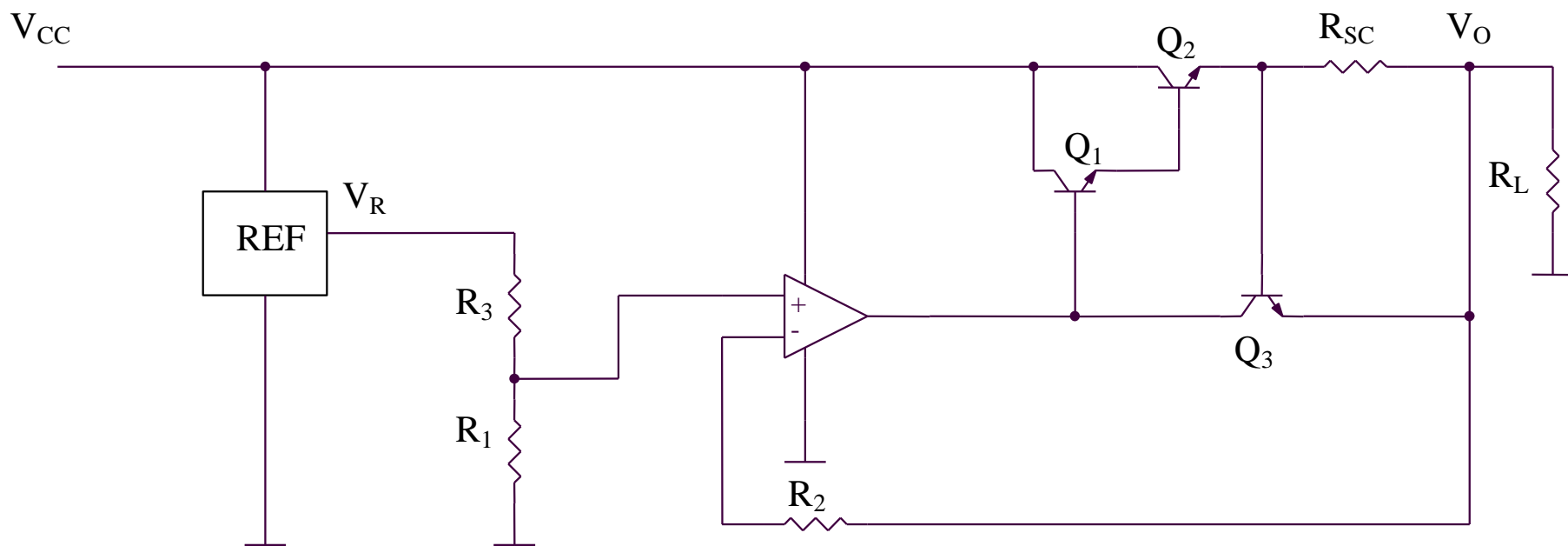

$$V_O = V_R \frac{R_1}{R_1 + R_3} < V_R$$

$$I_{Osc} = \frac{V_{BE}}{R_{sc}}$$

## Sursa de tensiune pentru $V_O > V_R$

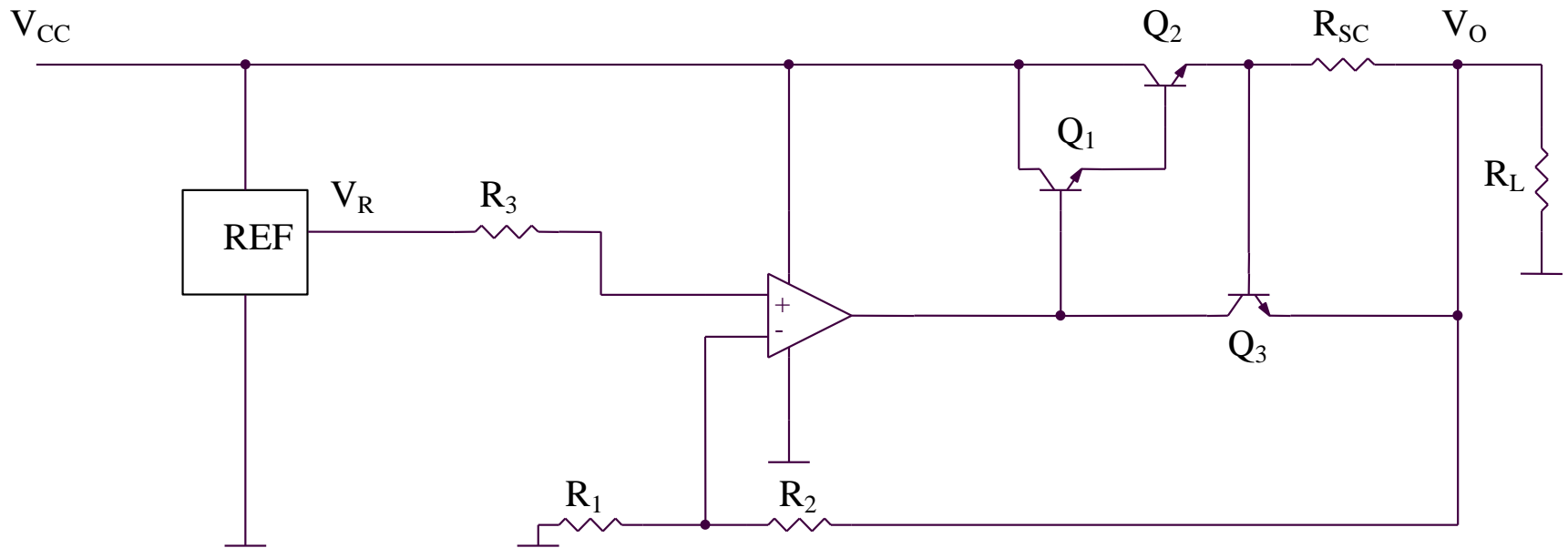

$$V_O \frac{R_1}{R_1 + R_2} = V_R \Rightarrow V_O = V_R \left( 1 + \frac{R_2}{R_1} \right) > V_R$$

$$I_{Osc} = \frac{V_{BE}}{R_{sc}}$$



### **3.2.3. Surse de tensiune compensate cu temperatura**

### 3.2.3. Surse de tensiune compensate cu temperatura

#### Referinte de tensiune bandgap (banda interzisa)

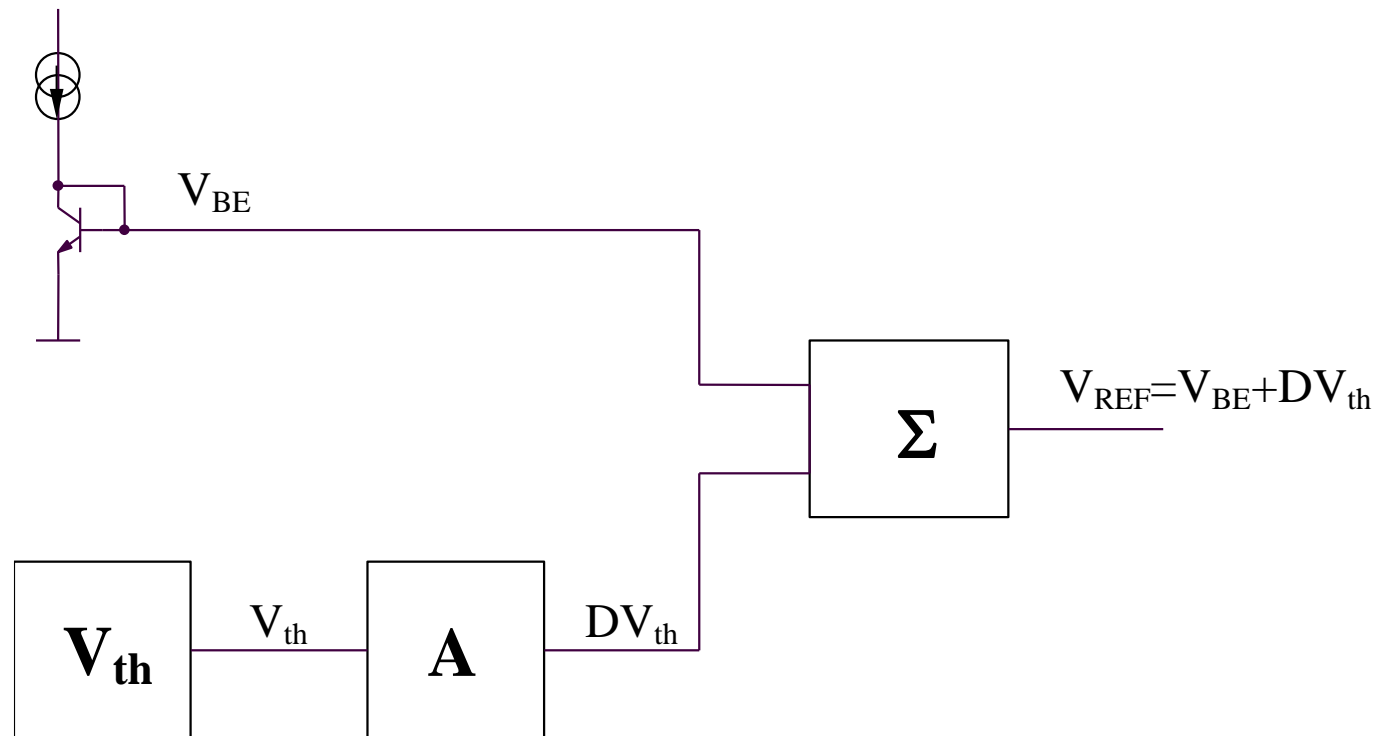

## Dependenta de temperatura a tensiunii $V_{BE}$

$$\left. \begin{aligned} V_{BE}(T) &= V_{th} \ln \left[ \frac{I_C(T)}{I_S(T)} \right] \\ I_S(T) &= CT^\eta \exp \left( -\frac{E_{GO}}{V_{th}} \right) \end{aligned} \right\} \Rightarrow V_{BE}(T) = E_{GO} + \frac{kT}{q} \ln \left[ \frac{I_C(T)}{CT^\eta} \right]$$

$$\left. \begin{aligned} V_{BE}(T_0) &= E_{GO} + \frac{kT_0}{q} \ln \left[ \frac{I_C(T_0)}{CT_0^\eta} \right] \\ I_C(T) &= BT^\alpha \end{aligned} \right\} \Rightarrow$$

$$\Rightarrow V_{BE}(T) = E_{GO} + \frac{V_{BE}(T_0) - E_{GO}}{T_0} T + (\alpha - \eta) \frac{KT}{q} \ln \left( \frac{T}{T_0} \right)$$

$$\frac{V_{BE}(T_0) - E_{GO}}{T_0} \cong -2,1mV / K < 0$$

# Functionarea referintelor de tensiune

$$\left. \begin{aligned} V_{REF}(T) &= DV_{th} + V_{BE}(T) \\ V_{BE}(T) &= A + BT + CT \ln\left(\frac{T}{T_0}\right) \end{aligned} \right\} \Rightarrow$$

$$\Rightarrow V_{REF}(T) = A + \left(B + D\frac{k}{q}\right)T + CT \ln\left(\frac{T}{T_0}\right)$$

$$B + D\frac{k}{q} = 0 \Rightarrow V_{REF}(T) = A + CT \ln\left(\frac{T}{T_0}\right)$$

# Referinta de tensiune (1)

$$I_1 = \frac{V_{BE2} - V_{BE1}}{R_3} = \frac{kT}{qR_3} \ln\left(\frac{I_2}{I_1}\right) \Rightarrow$$

$$I_1 R_1 = I_2 R_2$$

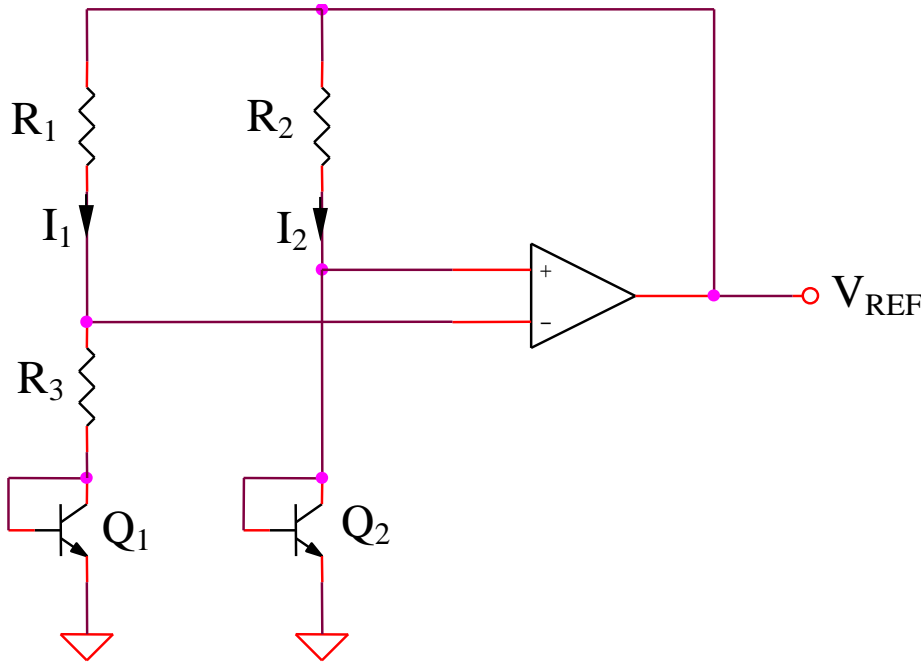

$$\Rightarrow I_1 = \frac{kT}{qR_3} \ln\left(\frac{R_1}{R_2}\right)$$

$$V_{REF}(T) = I_1(T)R_1 + V_{BE2}(T)$$

$$V_{BE}(T) = A + BT + CT \ln\left(\frac{T}{T_0}\right) \Rightarrow$$

$$\Rightarrow V_{REF}(T) = A + \left[ B + \frac{k}{q} \frac{R_1}{R_3} \ln\left(\frac{R_1}{R_2}\right) \right] T + CT \ln\left(\frac{T}{T_0}\right)$$

$$B + \frac{k}{q} \frac{R_1}{R_3} \ln\left(\frac{R_1}{R_2}\right) = 0 \Rightarrow V_{REF}(T) = A + CT \ln\left(\frac{T}{T_0}\right) \cong A \cong 1,2V$$

$V_{REF}$

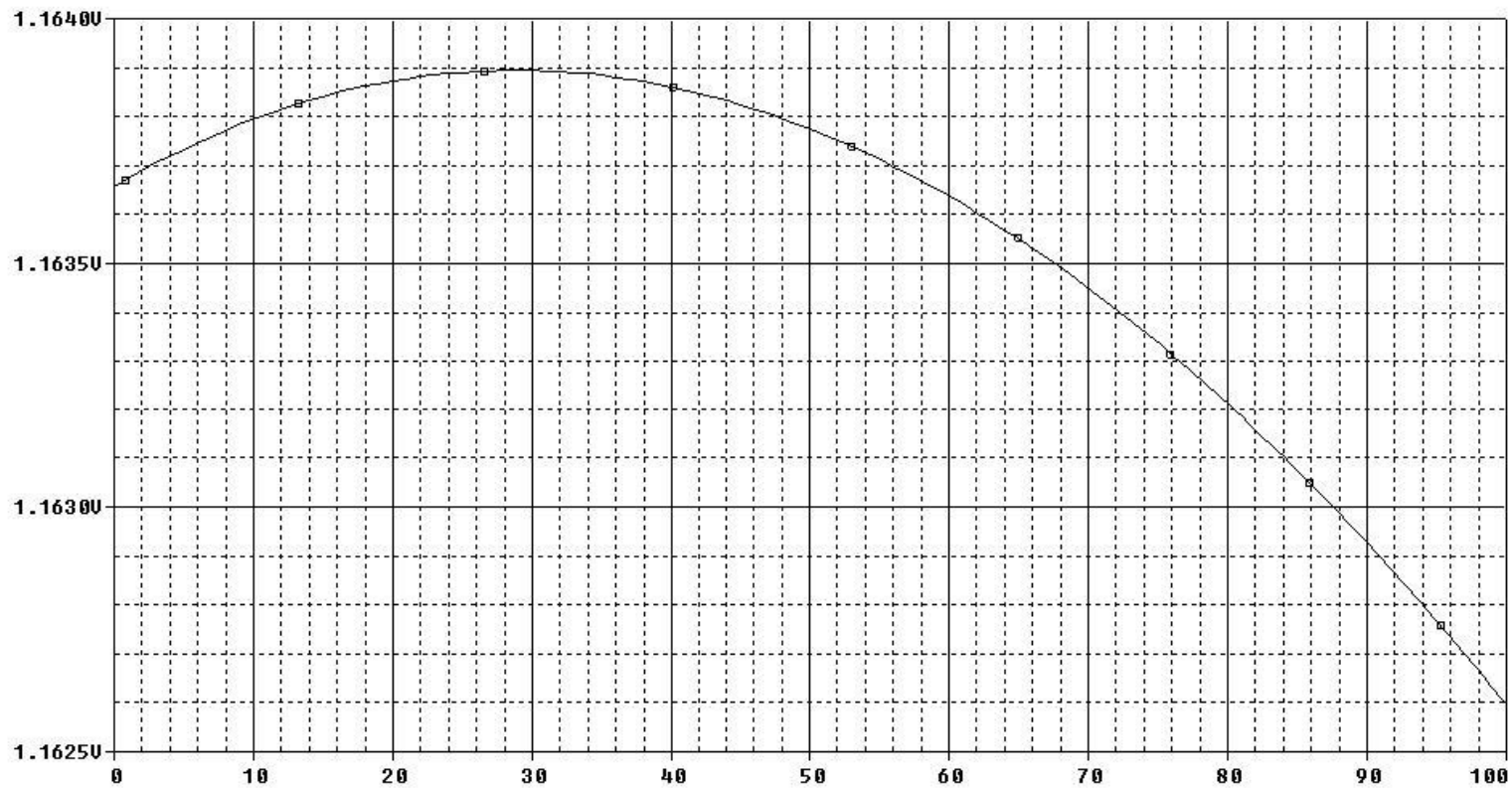

t

## Referinta de tensiune (2)

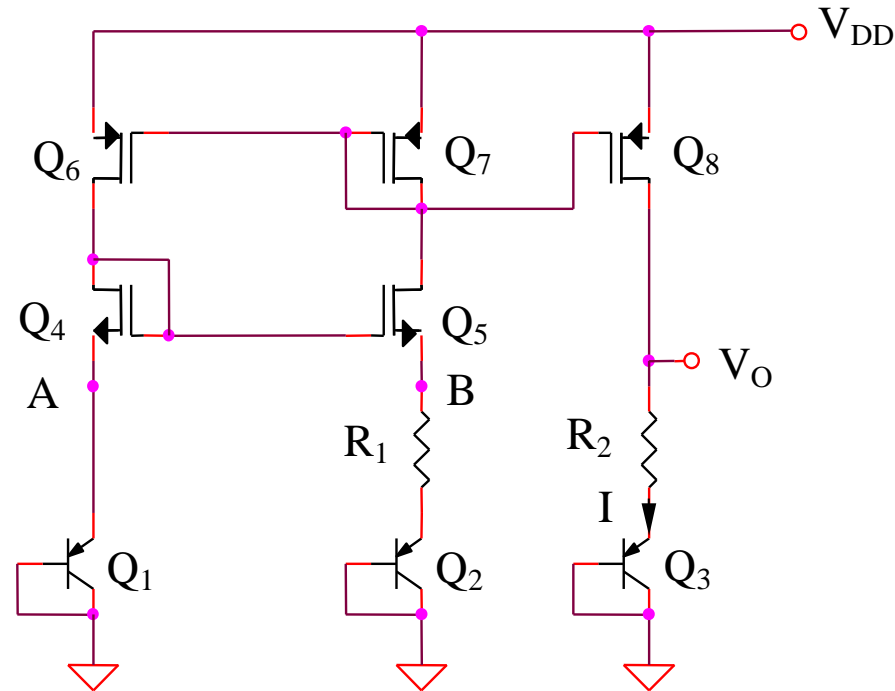

$$V_A - V_B = V_{GS5} - V_{GS4} = (V_{GS5} - V_T) - (V_{GS4} - V_T) = \sqrt{\frac{2I_{D5}}{K_5}} - \sqrt{\frac{2I_{D4}}{K_4}}$$

$$V_A - V_B = \sqrt{\frac{2I_{D5}}{K_5}} \left( 1 - \sqrt{\frac{I_{D4} K_5}{I_{D5} K_4}} \right) = \sqrt{\frac{2I_{D5}}{K_5}} \left( 1 - \sqrt{\frac{I_{D6} (W/L)_5}{I_{D7} (W/L)_4}} \right)$$

$$V_A - V_B = \sqrt{\frac{2I_{D5}}{K}} \left( 1 - \sqrt{\frac{(W/L)_5 (W/L)_6}{(W/L)_4 (W/L)_7}} \right)$$

Pentru:  $\frac{(W/L)_4}{(W/L)_5} = \frac{(W/L)_6}{(W/L)_7} \Rightarrow V_A = V_B$

$$\Rightarrow V_O(T) = /V_{BE_3}(T)/ + I(T)R_2 = /V_{BE_3}(T)/ + \frac{/V_{BE_1}(T)/ - /V_{BE_2}(T)/}{R_1} R_2$$

$$V_O(T) = /V_{BE_3}(T)/ + \frac{R_2}{R_1} \frac{kT}{q} \ln \frac{I_{D6}}{I_{D7}}$$

$$V_O(T) = /V_{BE_3}(T)/ + \frac{R_2}{R_1} \frac{kT}{q} \ln \left[ \frac{(W/L)_6}{(W/L)_7} \right]$$

$$/V_{BE}(T)/ = A + BT + CT \ln \left( \frac{T}{T_0} \right)$$

$$B + \frac{R_2}{R_1} \frac{k}{q} \ln \left[ \frac{(W/L)_6}{(W/L)_7} \right] = 0$$

$$\Rightarrow V_O(T) = A + CT \ln \left( \frac{T}{T_0} \right)$$



**SIMULARE pentru referinta de tensiune (2)**  
**Dependenta de temperatura a tensiunii de referinta**

# SIMULARE pentru referinta de tensiune (2)

## Dependenta de temperatura a tensiunii de referinta

SIM 3.13:  $V_{D5}(t)$

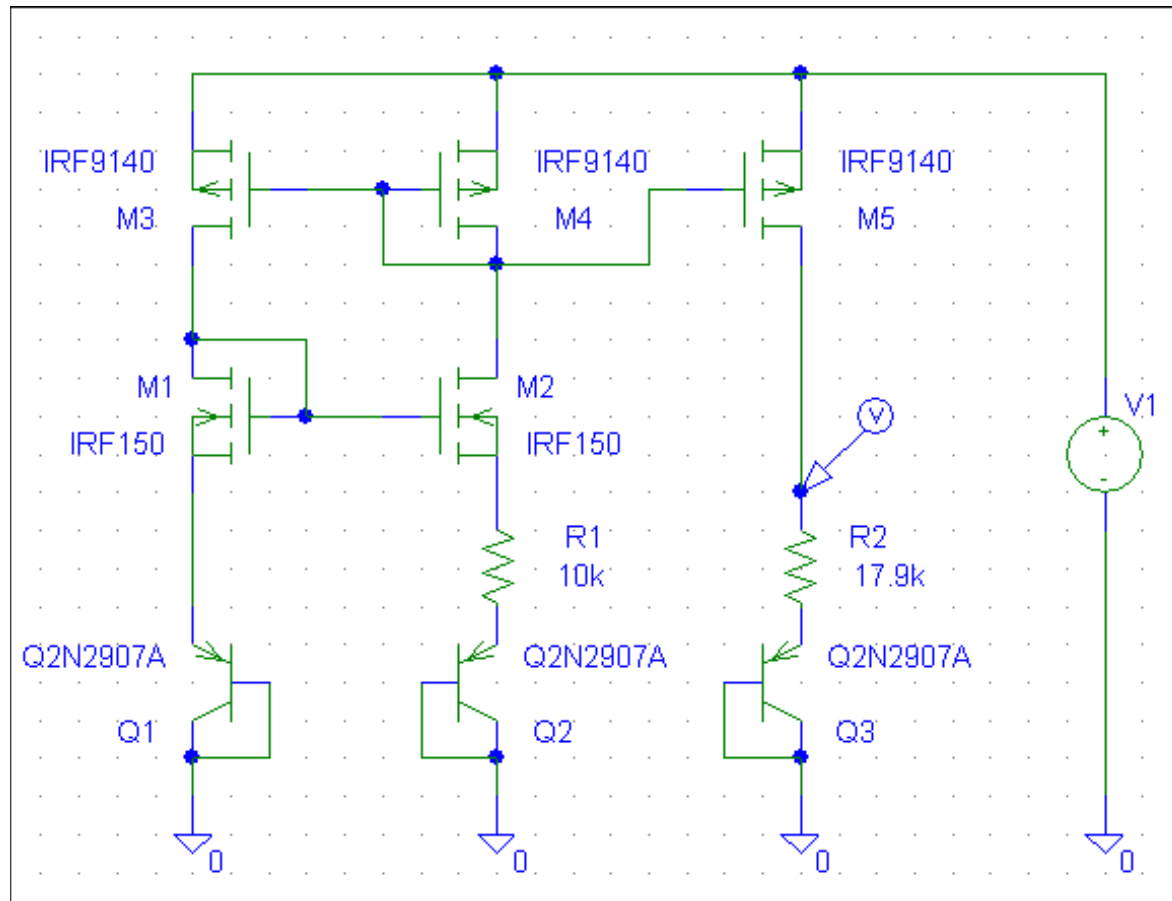

# Referinta de tensiune (3)

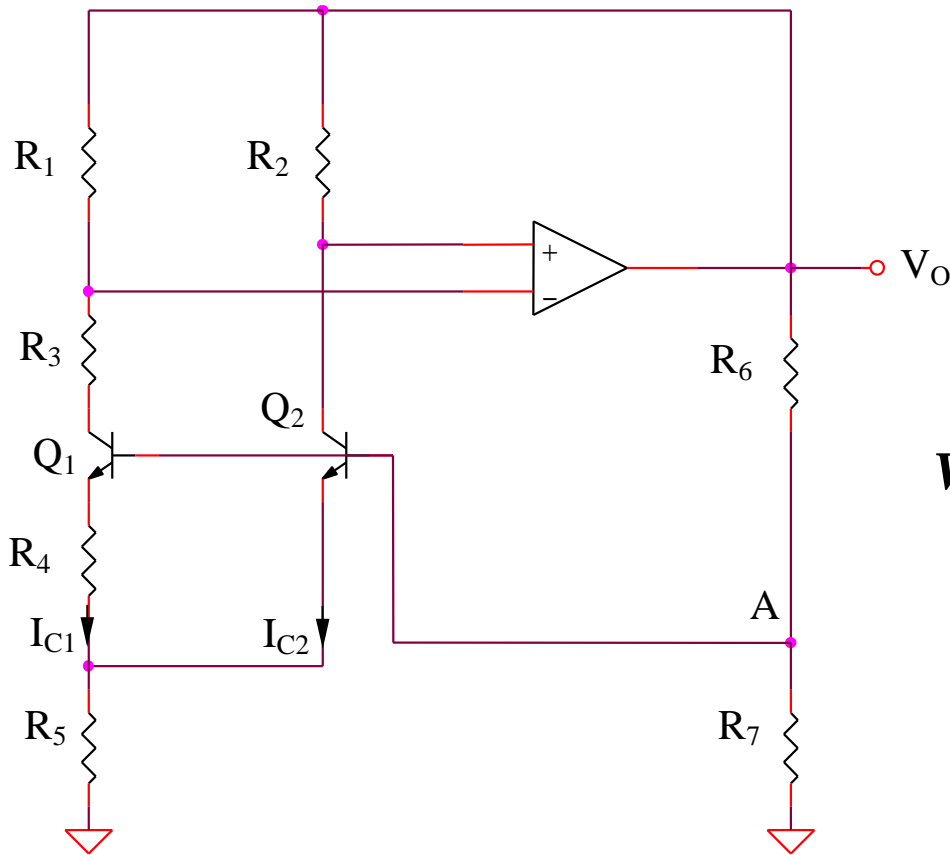

$$I_{C1} = \frac{V_{BE2} - V_{BE1}}{R_4} = \frac{V_{th}}{R_4} \ln \frac{I_{C2}}{I_{C1}} \quad \Rightarrow$$

$$I_{C1} R_1 = I_{C2} R_2$$

$$\Rightarrow I_{C1} = \frac{V_{th}}{R_4} \ln \frac{R_1}{R_2}$$

$$V_A(T) = (I_{C1} + I_{C2})R_5 + V_{BE2}(T)$$

$$V_A(T) = V_O(T) \frac{R_7}{R_6 + R_7} \quad \Rightarrow$$

$$\Rightarrow V_O(T) = \left( 1 + \frac{R_6}{R_7} \right) \left[ V_{BE2}(T) + \frac{R_5}{R_4} \left( 1 + \frac{R_1}{R_2} \right) V_{th} \ln \left( \frac{R_1}{R_2} \right) \right]$$

$$\frac{R_5}{R_4} \left( 1 + \frac{R_1}{R_2} \right) \frac{k}{q} \ln \left( \frac{R_1}{R_2} \right) + B = 0 \quad \Rightarrow V_O(T) = \left( 1 + \frac{R_6}{R_7} \right) \left[ A + CT \ln \left( \frac{T}{T_0} \right) \right]$$

# Senzori de temperatura

## Exemplu (1)

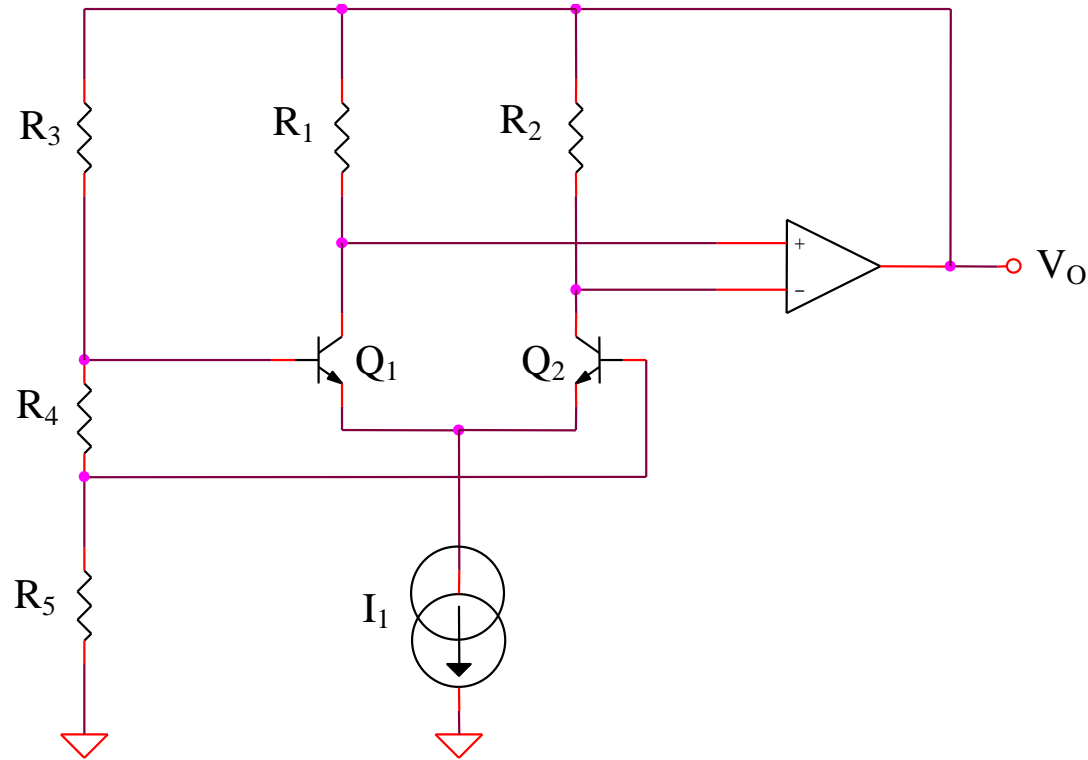

$$V_O(T) \frac{R_4}{R_3 + R_4 + R_5} = V_{BE1} - V_{BE2} = V_{th} \ln \frac{I_{C1}}{I_{C2}} = V_{th} \ln \frac{R_2}{R_1} \Rightarrow$$

$$\Rightarrow V_O(T) = \left( 1 + \frac{R_3 + R_5}{R_4} \right) V_{th} \ln \left( \frac{R_2}{R_1} \right) = ct.T$$

## Exemplu (2)

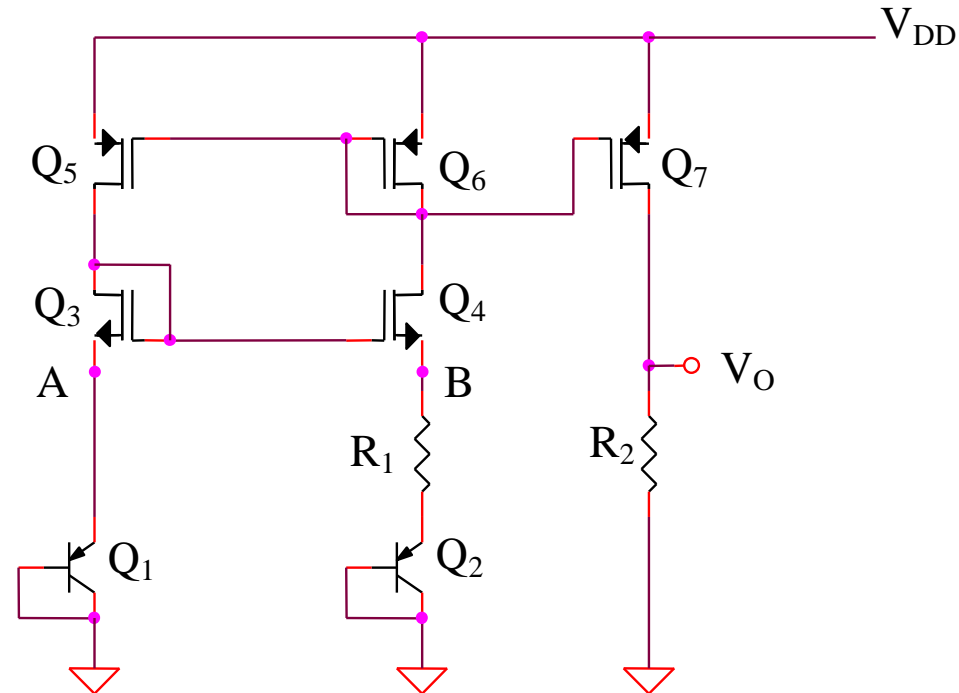

$$V_O = R_2 I_{D7}(T) = R_2 I_{D4}(T) = R_2 \frac{|V_{BE1}| - |V_{BE2}|}{R_1} = \frac{R_2}{R_1} V_{th} \ln \left[ \frac{(W/L)_5}{(W/L)_6} \right] = ct \cdot T$$

## Exemplu (3) – circuit de extragere a tensiunii de prag

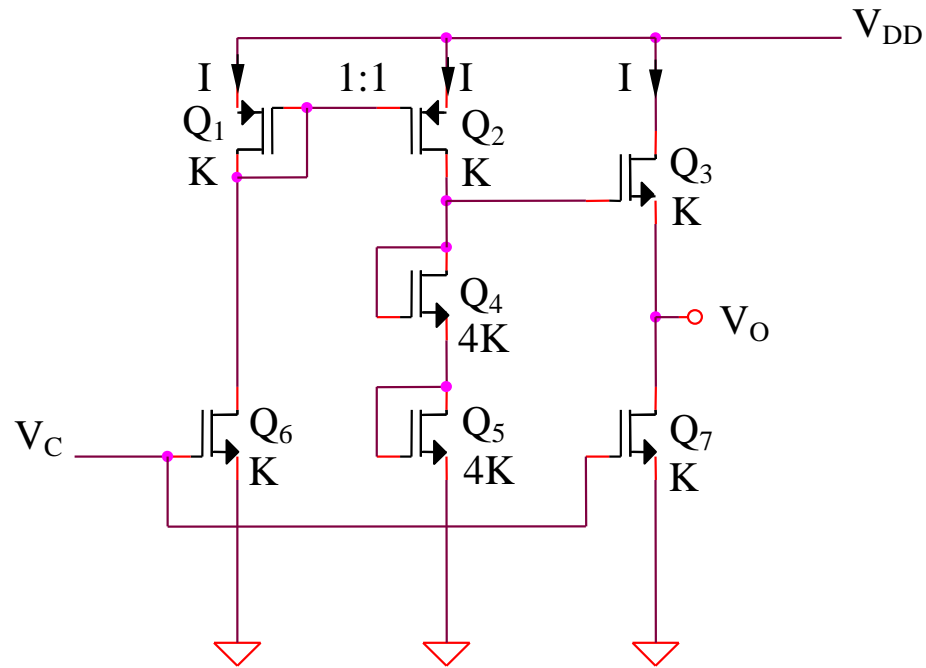

$$V_O = 2V_{GS_4} - V_{GS_3} = 2\left(V_T + \sqrt{\frac{2I}{4K}}\right) - \left(V_T + \sqrt{\frac{2I}{K}}\right) = V_T = V_{T0} + a(T - T_0)$$