

Capitolul 3

Surse de curent si surse de tensiune

3.1. Surse de curent

3.1. Surse de curent

3.1.1. Introducere

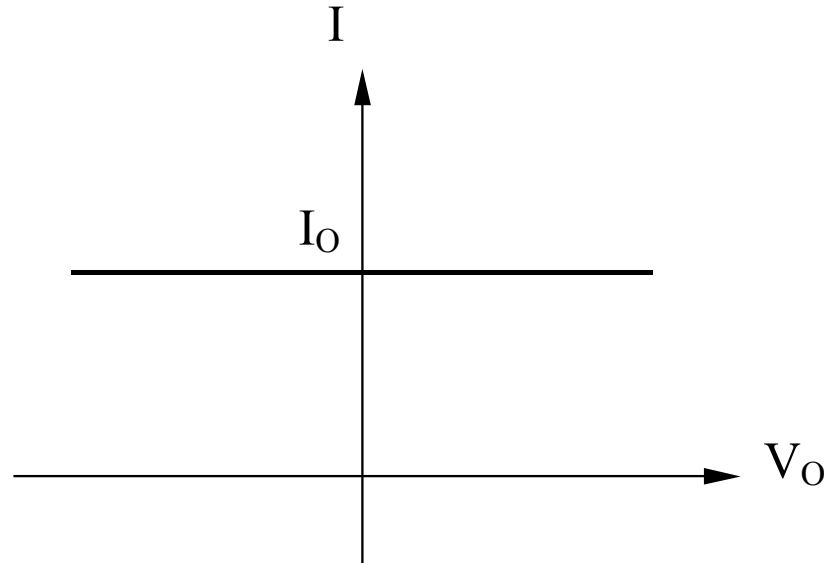
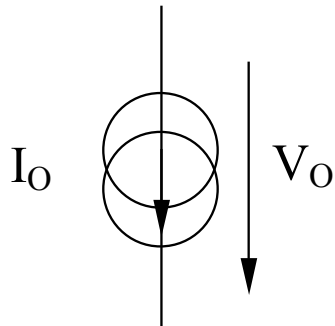

Parametri:

- Curentul de iesire I_O [A]
- Rezistenta de iesire [Ω]

$$R_O = \left. \frac{dV_O}{dI_O} \right|_{V_{CC}, T=ct.}$$

- Tensiunea minima de iesire [V]
- Coeficientul de temperatura [A/K]

$$TC_{I_O} = \left. \frac{dI_O}{dT} \right|_{R_L, V_{CC}=ct.}$$

- Coeficientul relativ de temperatura [1/K]

$$RTC_{I_O} = \left. \frac{1}{I_O} \frac{dI_O}{dT} \right|_{R_L, V_{CC}=ct.}$$

- Factorul de rejectie al tensiunii de alimentare (Power Supply Rejection Ratio) [A/V]

$$PSRR = \left. \frac{dI_O}{dV_{CC}} \right|_{R_L, T=ct.}$$

- Sensibilitatea curentului de iesire in raport cu variatiile tensiunii de alimentare [-]

$$S_{V_{CC}}^{I_O} = \left. \frac{dI_O / I_O}{dV_{CC} / V_{CC}} \right|_{R_L, T=ct.} = \left. \frac{V_{CC}}{I_O} \frac{dI_O}{dV_{CC}} \right|_{R_L, T=ct.}$$

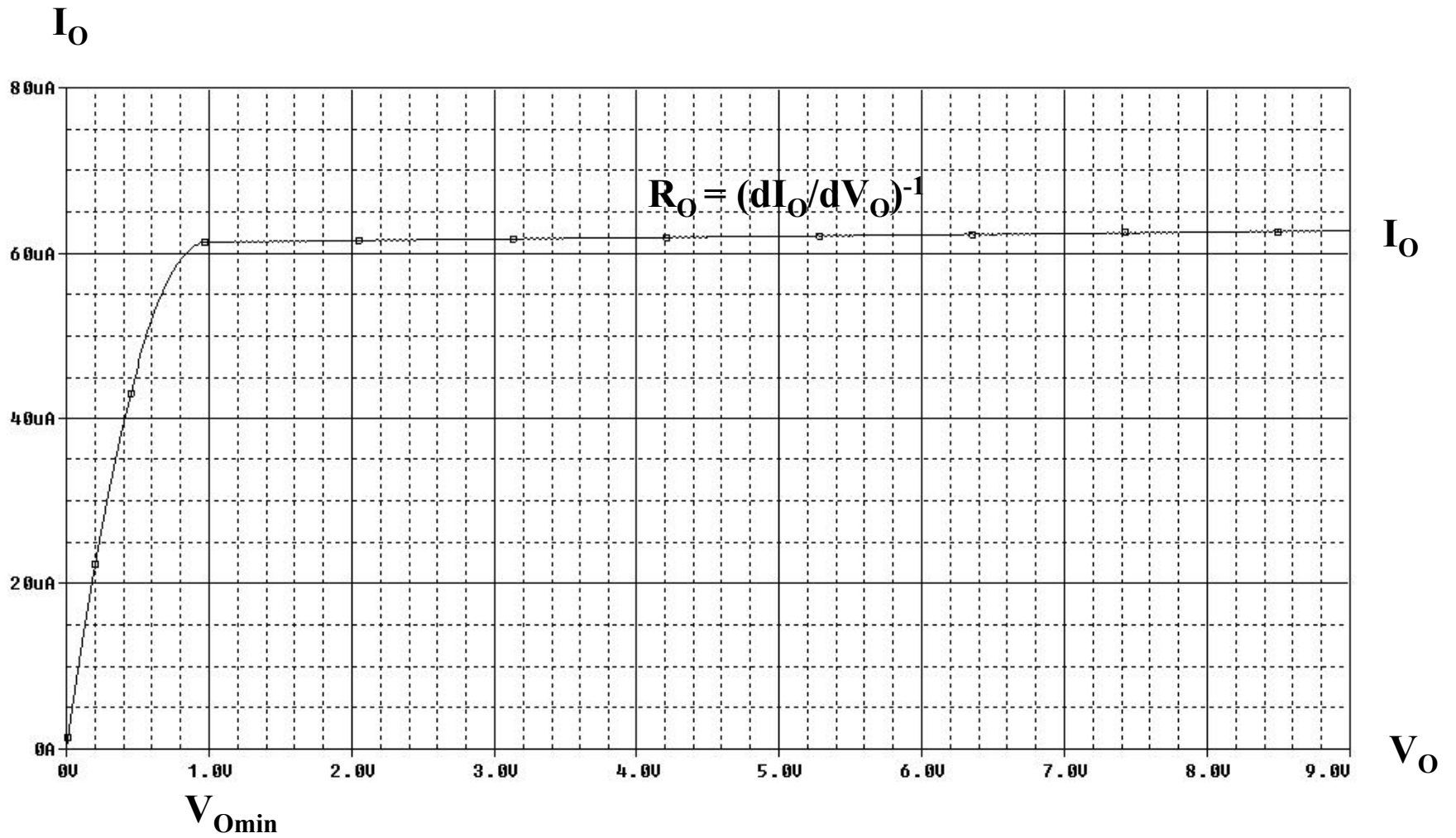

Caracteristica de iesire a unei surse de curent

Clasificare

I. Surse de curent elementare

- complexitate redusa
- performante modeste

II. Surse de curent cascod

- rezistenta de iesire mare
- tensiune minima de iesire mare
- tensiune minima de alimentare mare

III. Surse de curent cu autopolarizare

- dependenta redusa $I_O (V_{CC})$
- necesita circuit de pornire

IV. Surse de curent compensate cu temperatura

- dependenta redusa de temperatura
- complexitate ridicata

3.1.2. Surse de curent elementare

3.1.2. Surse de curent elementare

Sursa de curent CMOS cu un tranzistor

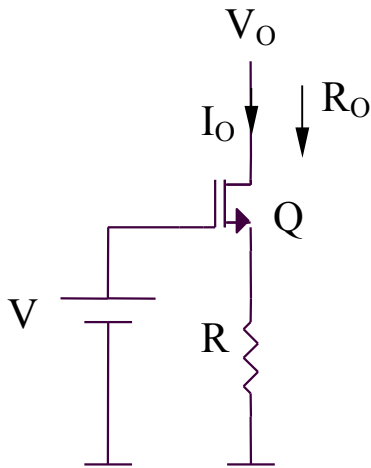

$$\left. \begin{aligned} V &= V_{GS} + I_O R \\ I_O &= \frac{K}{2} (V_{GS} - V_T)^2 \end{aligned} \right\} \Rightarrow V = V_{GS} + \frac{KR}{2} (V_{GS} - V_T)^2$$
$$\Rightarrow V_{GS} (> V_T) \Rightarrow I_O$$

$$R_O = r_{ds} (1 + g_m R)$$

$$V_{O\min} = V - V_{GS} + (V_{GS} - V_T) = V - V_T$$

Sursa de curent bipolară cu un tranzistor

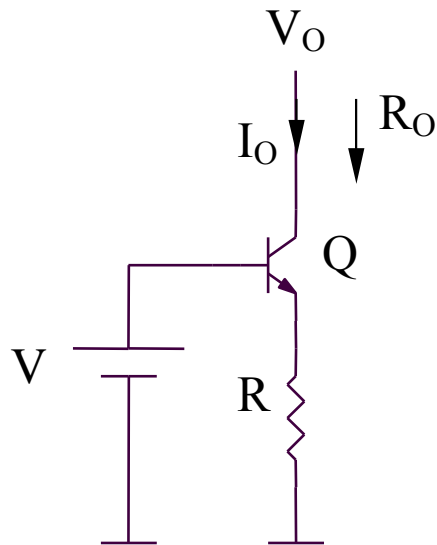

$$I_O = \frac{V - V_{BE}}{R}$$

$$R_O = r_o \left(1 + \frac{\beta R}{r_\pi + R} \right)$$

$$V_{O\min} = V - V_{BE} + V_{CEsat}$$

Oglinda de curent CMOS

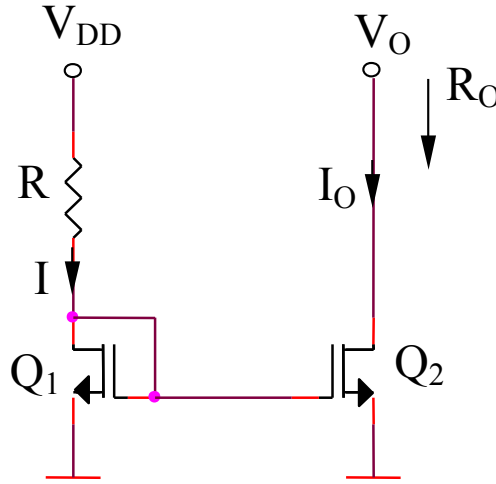

Curentul de iesire

$$\left. \begin{aligned} V_{DD} &= I_O R + V_{GS1} \\ I_O &= \frac{K}{2} (V_{GS1} - V_T)^2 \end{aligned} \right\} \Rightarrow V_{DD} = \frac{KR}{2} (V_{GS1} - V_T)^2 + V_{GS1} \Rightarrow$$

$$\Rightarrow (V_{GS1})_{1,2} = V_T - \frac{1}{KR} \pm \frac{1}{KR} \sqrt{1 + 2KR(V_{DD} - V_T)}$$

V_{GS} trebuie sa fie mai mare decat V_T :

$$V_{GS1} = V_T - \frac{1}{KR} + \frac{1}{KR} \sqrt{1 + 2KR(V_{DD} - V_T)}$$

$$\Rightarrow I_O = \frac{1}{KR^2} \left[1 + KR(V_{DD} - V_T) - \sqrt{1 + 2KR(V_{DD} - V_T)} \right]$$

Rezistenta de iesire

$$R_O = r_{ds2} = \frac{1}{\lambda I_O}$$

Tensiunea minima de iesire

$$V_{O\min} = V_{DS2sat} = V_{GS2} - V_T = \sqrt{\frac{2I_O}{K}}$$

Efectul de modulare a lungimii canalului

$$\frac{I_O}{I} = \frac{\frac{K}{2} (V_{GS2} - V_T)^2 (1 + \lambda V_{DS2})}{\frac{K}{2} (V_{GS1} - V_T)^2 (1 + \lambda V_{DS1})} = \frac{1 + \lambda V_{DS2}}{1 + \lambda V_{DS1}} = \frac{1 + \lambda V_O}{1 + \lambda V_{GS1}}$$

SIMULARI pentru oglinda de curent CMOS
Caracteristica de iesire

SIMULARI pentru oglinda de curent CMOS

Caracteristica de iesire

SIM 3.1: I_{D2} (V2)

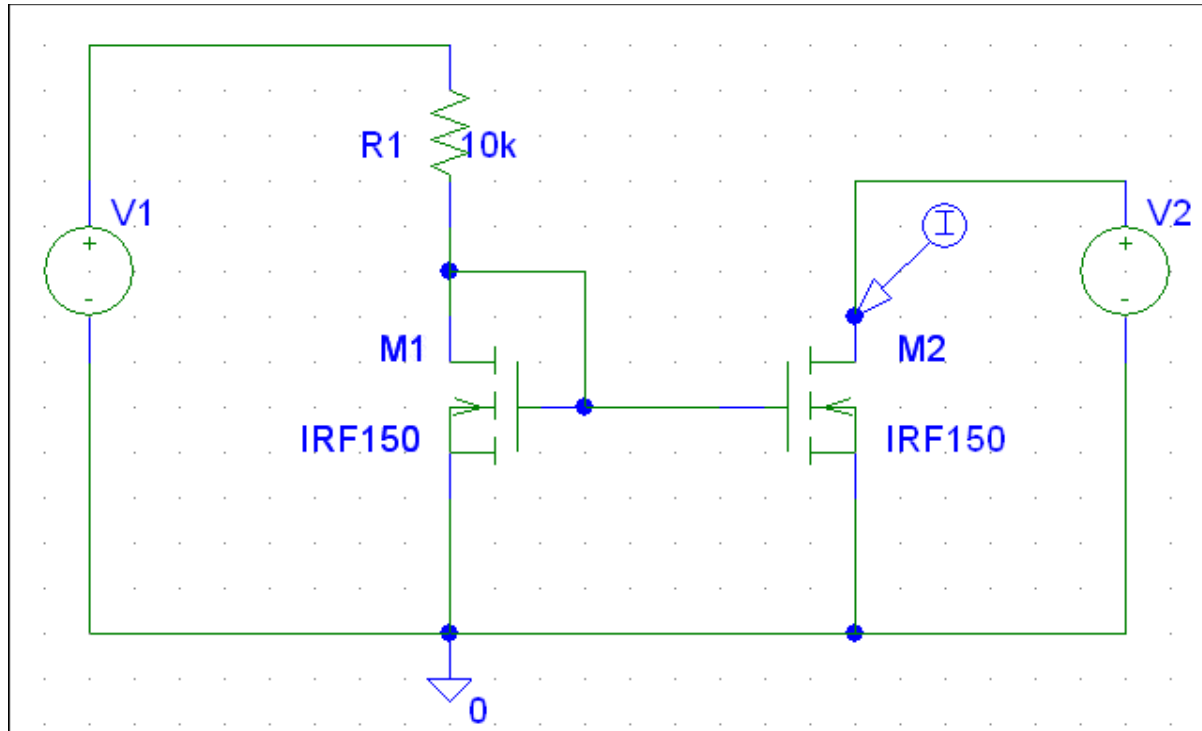

SIMULARI pentru oglinda de curent CMOS

Caracteristica de iesire

SIM 3.2: I_{D2} (V2), r_{ds2} - parametru

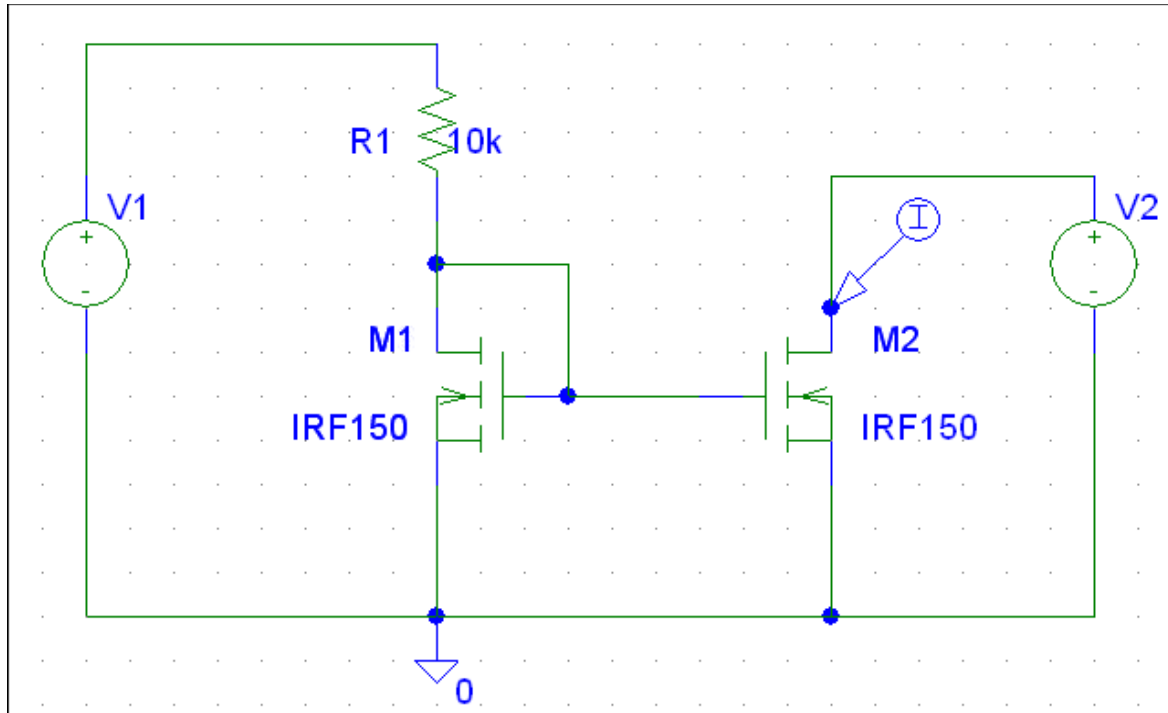

SIMULARI pentru oglinda de curent CMOS

Dependenta curentului de iesire de tensiunea de alimentare

SIMULARI pentru oglinda de curent CMOS

Dependenta curentului de iesire de tensiunea de alimentare

SIM 3.3: I_{D2} (V1)

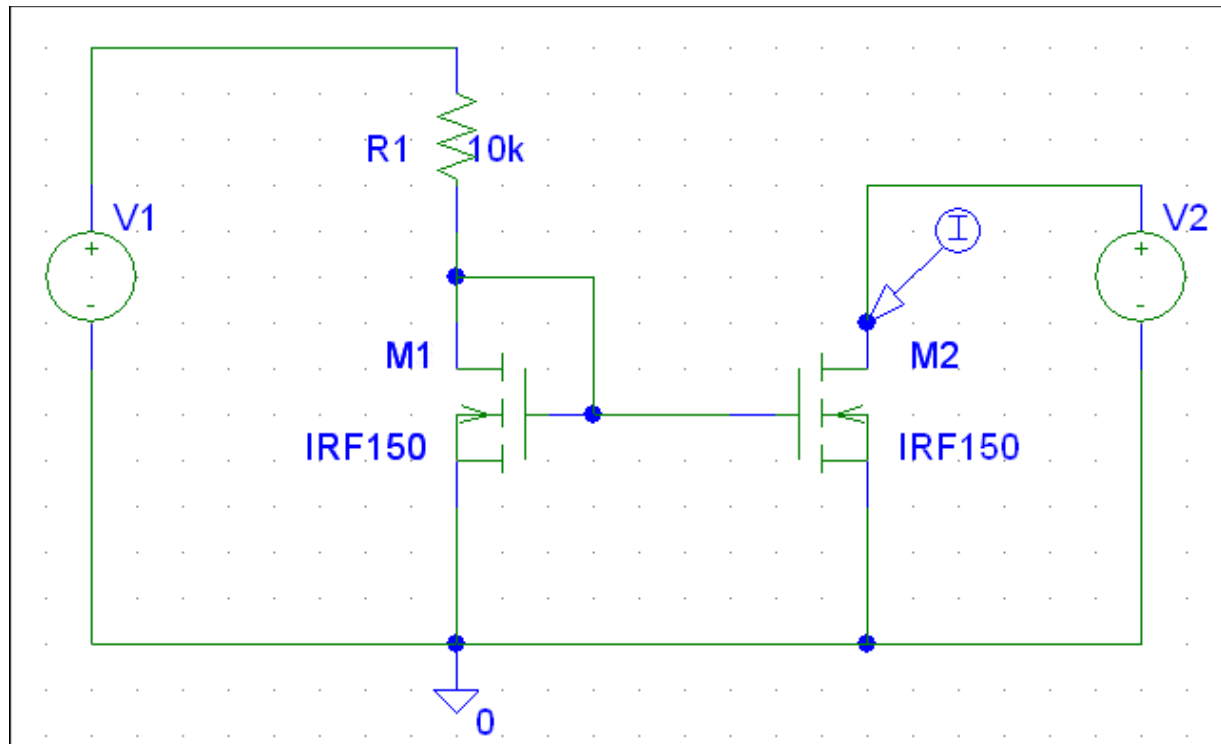

Oglinda de curent bipolarara

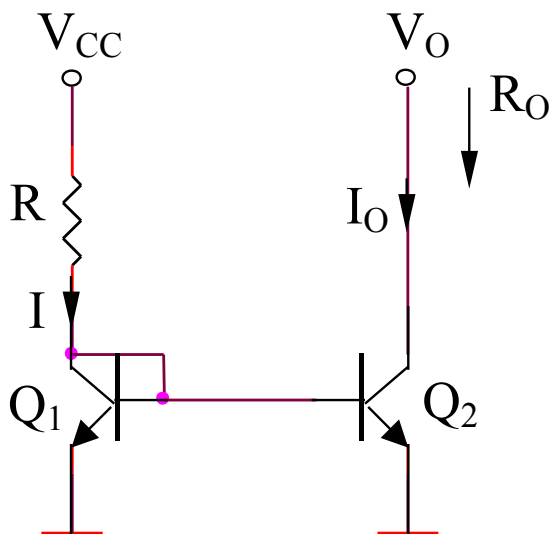

Curent de iesire

$$\left. \begin{aligned} I &= \frac{V_{CC} - V_{BE}}{R} \cong I_{S1} \exp\left(\frac{V_{BE1}}{V_{th}}\right) \\ I_O &\cong I_{S2} \exp\left(\frac{V_{BE2}}{V_{th}}\right) \\ V_{BE1} &= V_{BE2} \end{aligned} \right\} \Rightarrow \frac{I_O}{I} \cong \frac{I_{S2}}{I_{S1}} \Rightarrow I_O \cong \frac{V_{CC} - V_{BE}}{R} \frac{I_{S2}}{I_{S1}}$$

Rezistentă de iesire

$$R_O = r_o = \frac{V_A}{I_{C2}} = \frac{V_A}{I_O}$$

Tensiune minima de iesire

$$V_{O\min} = V_{CE2\text{sat.}}$$

Efect Early

$$I = \frac{V_{CC} - V_{BE}}{R} = I_{S1} \exp\left(\frac{V_{BE1}}{V_{th}}\right) \left(1 + \frac{V_{CE1}}{V_A}\right)$$

$$I_O = I_{S2} \exp\left(\frac{V_{BE2}}{V_{th}}\right) \left(1 + \frac{V_{CE2}}{V_A}\right)$$

$$\frac{I_O}{I} = \frac{I_{S2}}{I_{S1}} \frac{1 + \frac{V_{CE1}}{V_A}}{1 + \frac{V_{CE2}}{V_A}} = \frac{I_{S2}}{I_{S1}} \frac{1 + \frac{V_{BE1}}{V_A}}{1 + \frac{V_O}{V_A}}$$

Influenta β

$$\frac{I_O}{I} = \frac{\beta I_B}{\beta I_B + 2I_B} = \frac{\beta}{\beta + 2}$$

SIMULARI pentru oglinda de curent bipolară
Caracteristica de ieșire

SIMULARI pentru oglinda de curent bipolara

Caracteristica de iesire

SIM 3.4: I_{C1} (V2)

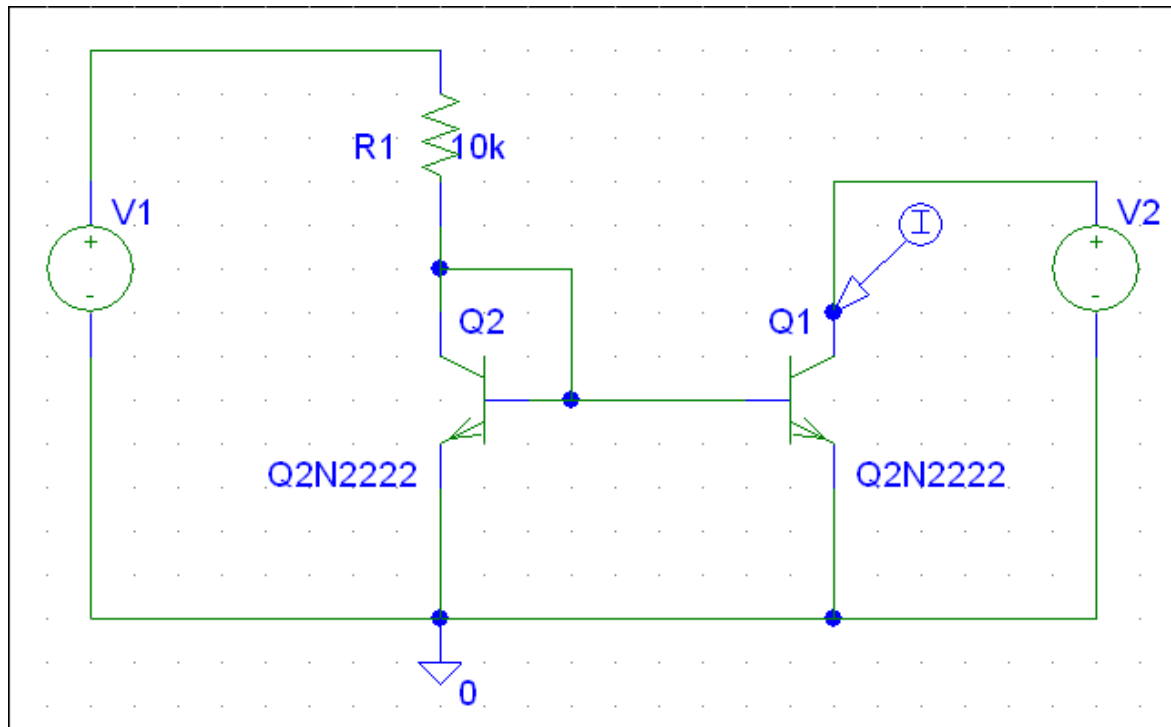

SIMULARI pentru oglinda de curent bipolara

Caracteristica de iesire

SIM 3.5: I_{C1} (V2), V_{A1} - parametru

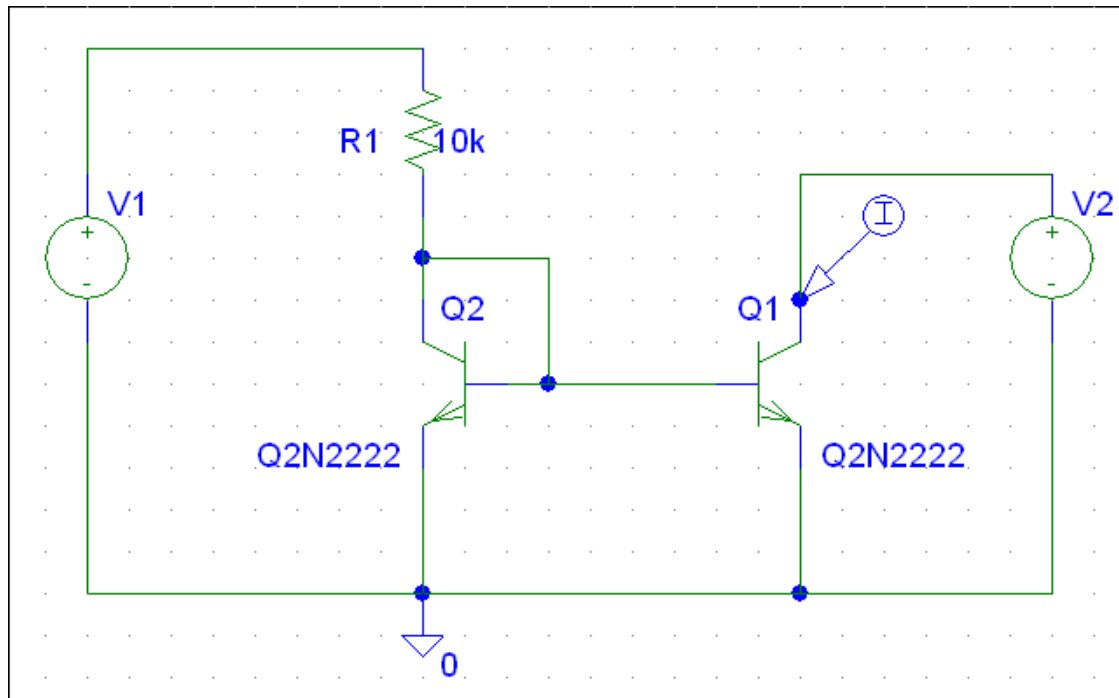

SIMULARI pentru oglinda de curent bipolară
Dependenta curentului de iesire de tensiunea de alimentare

SIMULARI pentru oglinda de curent bipolară Dependenta curentului de iesire de tensiunea de alimentare

SIM 3.6: I_{C1} (V1)

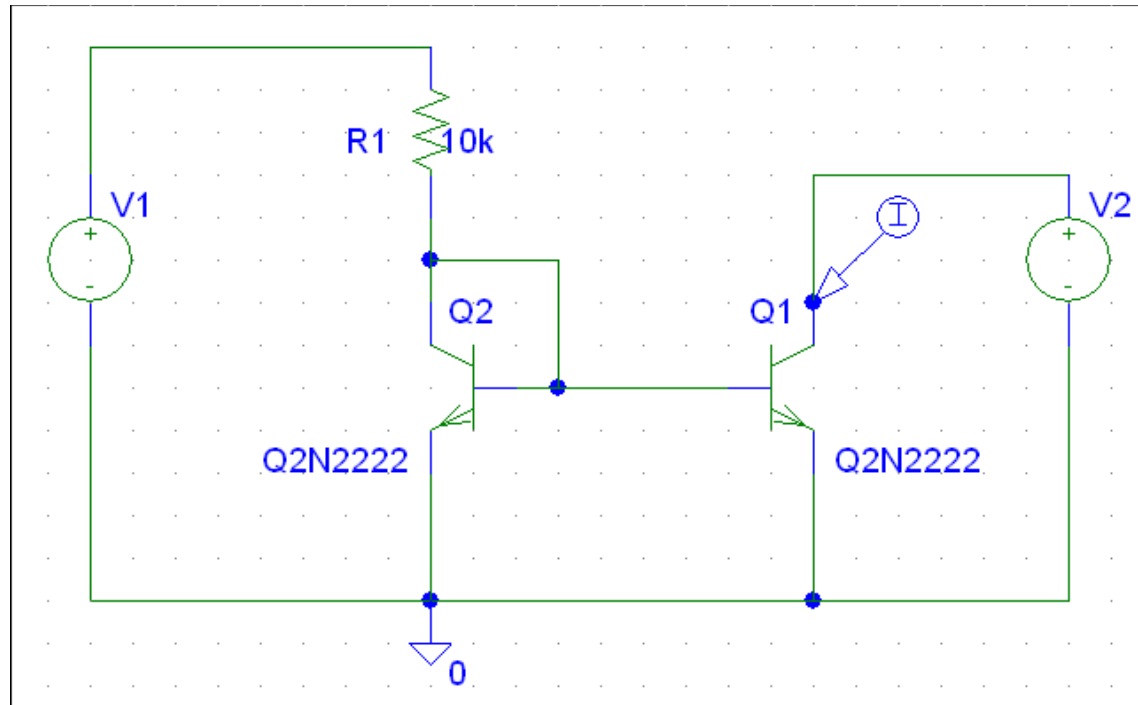

Sursa de curent cu reducerea efectului β (1)

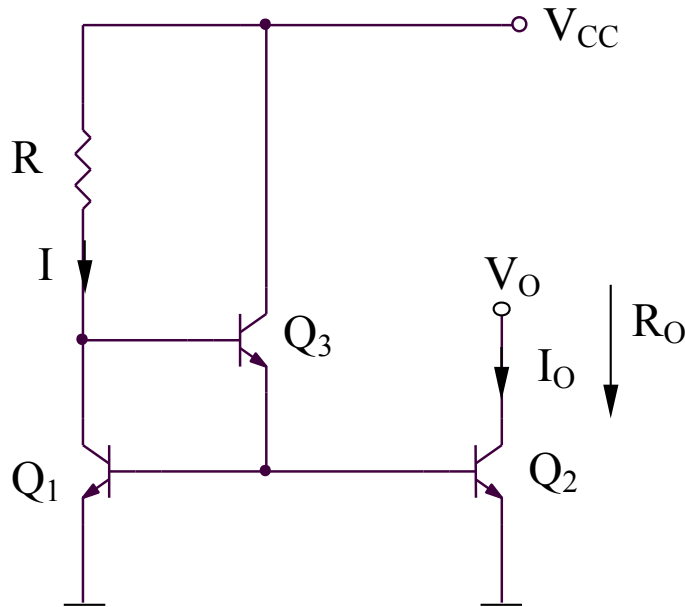

Curent de iesire

$$I_O \cong I = \frac{V_{CC} - 2V_{BE}}{R}$$

Rezistenta de iesire

$$R_O = r_o = \frac{V_A}{I_{C2}} = \frac{V_A}{I_O}$$

Tensiune minima de iesire

$$V_{O\min} = V_{CE2\text{sat.}}$$

Influenta β

$$\frac{I_O}{I} = \frac{\beta I_B}{\beta I_B + \frac{2I_B}{\beta + 1}} = \frac{1}{1 + \frac{2}{\beta^2 + \beta}} \cong 1$$

Sursa de curent cu reducerea efectului β (2)

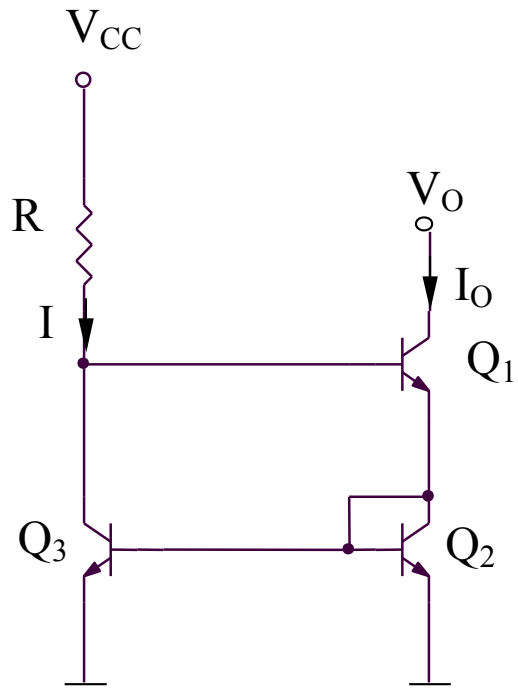

Curent de iesire

$$I_O \cong I = \frac{V_{CC} - 2V_{BE}}{R}$$

Tensiune minima de iesire

$$V_{O\min} = V_{BE2} + V_{CE1sat}.$$

Influenta β

$$\frac{I_O}{I} = \frac{\frac{\beta(\beta + 2)}{\beta + 1} I_B}{\beta I_B + \frac{\beta + 2}{\beta + 1} I_B} = \frac{1}{1 + \frac{2}{\beta^2 + 2\beta}} \cong 1$$

Sursa de curent multipla

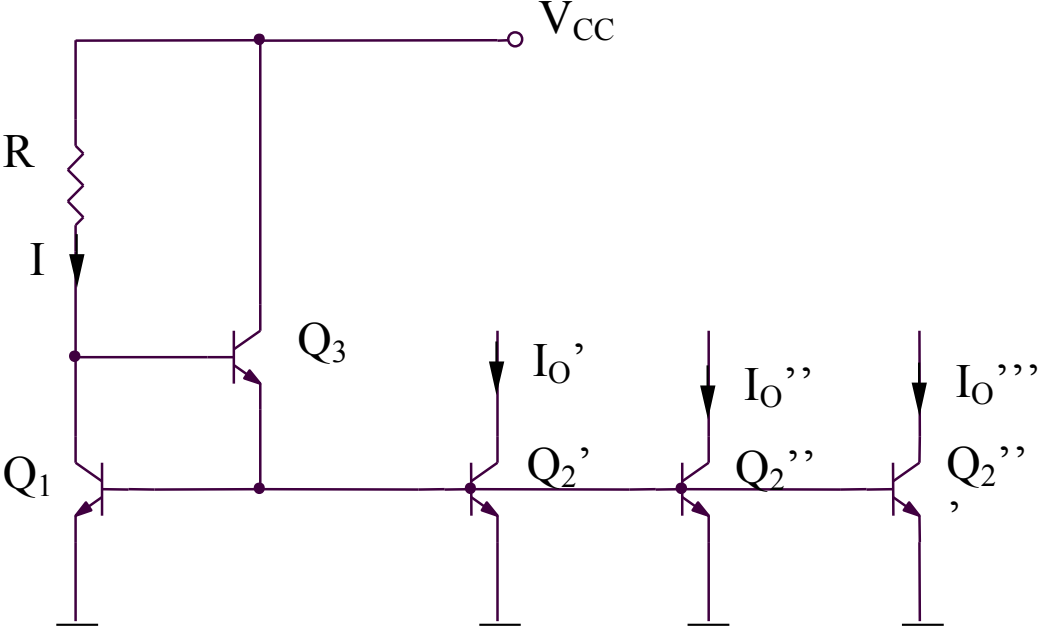

Sursa de curent Widlar bipolară

Curentul de iesire

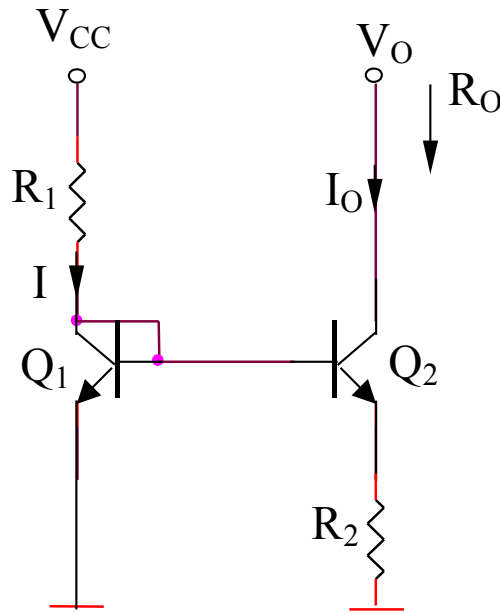

$$I = \frac{V_{CC} - V_{BE}}{R_1}$$

$$I_O = \frac{V_{BE1} - V_{BE2}}{R_2} = \frac{V_{th} \ln\left(\frac{I}{I_S}\right) - V_{th} \ln\left(\frac{I_O}{I_S}\right)}{R_2}$$

$$I_O = \frac{V_{th}}{R_2} \ln\left(\frac{I}{I_O}\right) = \frac{V_{th}}{R_2} \ln\left(\frac{V_{CC} - V_{BE}}{R_1 I_O}\right)$$

Tensiunea minima de iesire

$$V_{O \min} = V_{CE2 \text{ sat.}} + I_O R_2$$

Rezistenta de iesire

$$R_O = r_o \left(1 + \frac{\beta R_2}{r_{\pi 2} + R_2 + (1/g_{m1}) // R_1} \right) = \frac{V_A}{I_O} \left(1 + \frac{\beta R_2}{r_{\pi 2} + R_2 + (1/g_{m1}) // R_1} \right)$$

PSRR

$$\frac{dI_O}{dV_{CC}} = \frac{d}{dV_{CC}} \left[\frac{V_{th}}{R_2} \ln \left(\frac{V_{CC} - V_{BE}}{R_1 I_O} \right) \right]$$

$$\frac{dI_O}{dV_{CC}} = \frac{V_{th}}{R_2} \frac{R_1 I_O}{V_{CC} - V_{BE}} \frac{R_1 I_O - (V_{CC} - V_{BE}) R_1 \frac{dI_O}{dV_{CC}}}{(R_1 I_O)^2}$$

$$\frac{dI_O}{dV_{CC}} = \frac{1}{1 + \frac{V_{th}}{R_2 I_O}} \frac{V_{th}}{R_2 V_{CC} - V_{BE}}$$

Sensibilitatea curentului de iesire in raport cu variatiile tensiunii de alimentare

$$S_{V_{CC}}^{I_O} = \frac{V_{CC}}{I_O} \frac{dI_O}{dV_{CC}} = \frac{1}{1 + \frac{R_2 I_O}{V_{th}}} = \frac{1}{1 + \ln \left(\frac{V_{CC} - V_{BE}}{R_1 I_O} \right)}$$

Sursa de curent CMOS

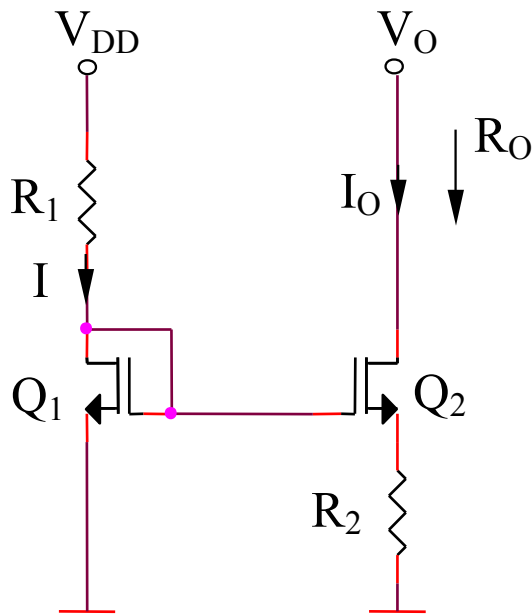

Curentul de iesire

$$V_{GS1} = V_T - \frac{1}{KR_1} + \frac{1}{KR_1} \sqrt{1 + 2KR_1 (V_{DD} - V_T)}$$

$$V_{GS1} = V_{GS2} + I_O R_2 = V_{GS2} + \frac{KR_2}{2} (V_{GS2} - V_T)^2$$

$$(V_{GS2} > V_T)$$

$$I_O = \frac{K}{2} (V_{GS2} - V_T)^2 (1 + \lambda V_{DS2})$$

Tensiunea minima de iesire

$$V_{O\min} = V_{DS2\text{sat}} + I_O R_2 = \sqrt{\frac{2I_O}{K}} + I_O R_2$$

Rezistenta de iesire

$$R_O = r_{ds2} (1 + g_{m2} R_2)$$

Sursa de curent standard

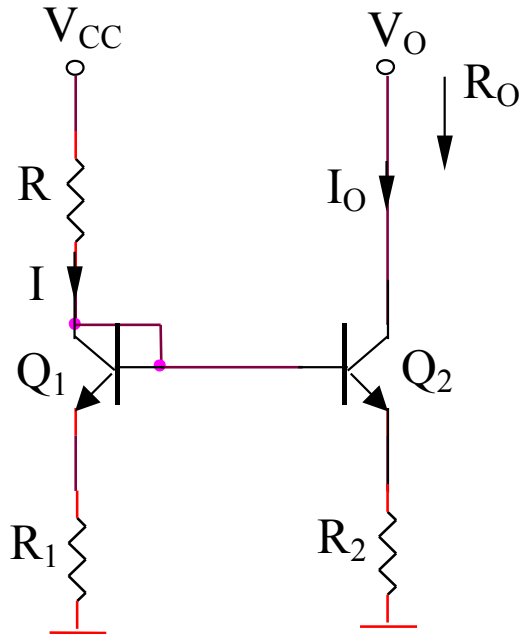

Curentul de iesire

$$v_{BE1} + R_1 I = v_{BE2} + R_2 I_O$$

$$I_O = \frac{I}{R_2} (R_1 I + v_{BE1} - v_{BE2})$$

$$\frac{I_O}{I} = \frac{R_1}{R_2} + \frac{V_{th}}{R_2 I} \ln \left(\frac{I}{I_O} \frac{I_{S2}}{I_{S1}} \right)$$

Se poate determina I/I_O deoarece:

$$I = \frac{V_{CC} - v_{BE}}{R + R_1}$$

Daca $R_1 I \gg v_{BE1} - v_{BE2}$:

$$\frac{I_O}{I} = \frac{R_1}{R_2}$$

Rezistenta de iesire

$$R_O = r_{o2} \left(1 + \frac{\beta R_2}{R_2 + r_{\pi 2} + R // (1/g_{m1} + R_1)} \right)$$

Sursa de curent standard cu iesire multipla

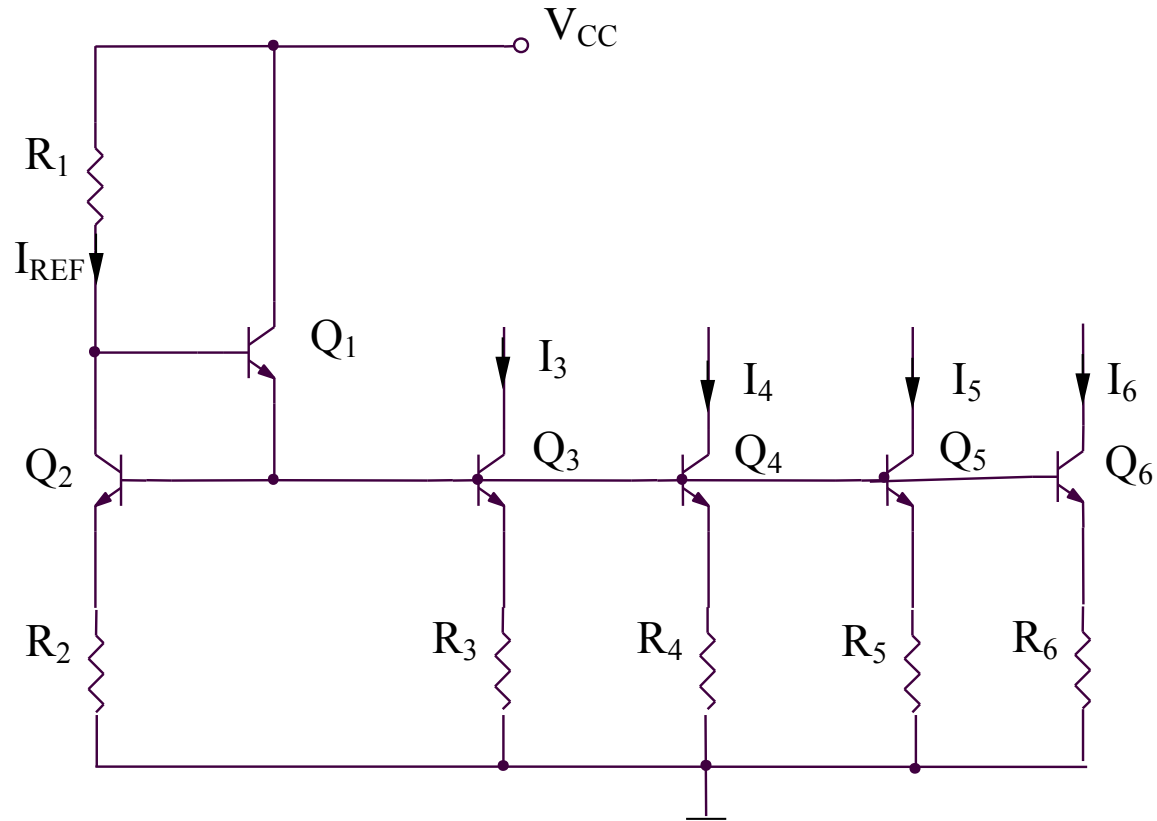

Daca ariile tranzistoarelor sunt alese in asa fel incat densitatile de curent sa fie egale, atunci tensiunile baza-emitor vor fi egale.

$$v_{BE2} - v_{BE3} = V_{th} \ln\left(\frac{I_{REF} I_{S3}}{I_3 I_{S2}}\right) = V_{th} \ln\left(\frac{jA_2 A_3}{jA_3 A_2}\right) = 0$$

Deci:

$$v_{BE2} = \dots = v_{BE6}$$

si:

$$I_3 R_3 = I_4 R_4 = I_5 R_5 = I_6 R_6 = I_{REF} R_2$$

Cei patru curenti de iesire au expresiile:

$$I_3 = I_{REF} \frac{R_2}{R_3}; \dots; I_6 = I_{REF} \frac{R_2}{R_6}$$

unde:

$$I_{REF} = \frac{V_{CC} - 2v_{BE}}{R_1 + R_2}$$

Sursa de curent utilizand ca referinta tensiunea baza-emitor

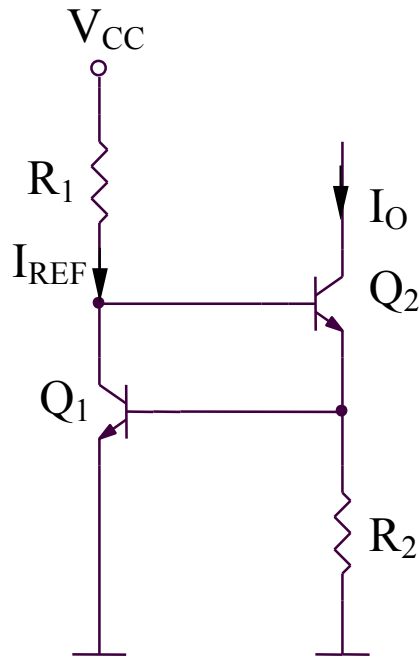

$$I_O = \frac{v_{BE1}}{R_2} = \frac{V_{th}}{R_2} \ln \frac{V_{CC} - 2v_{BE}}{R_1 I_S}$$

3.1.3. Surse de curent cascod

3.1.3. Surse de curent cascod

Sursa de curent cascod CMOS (1)

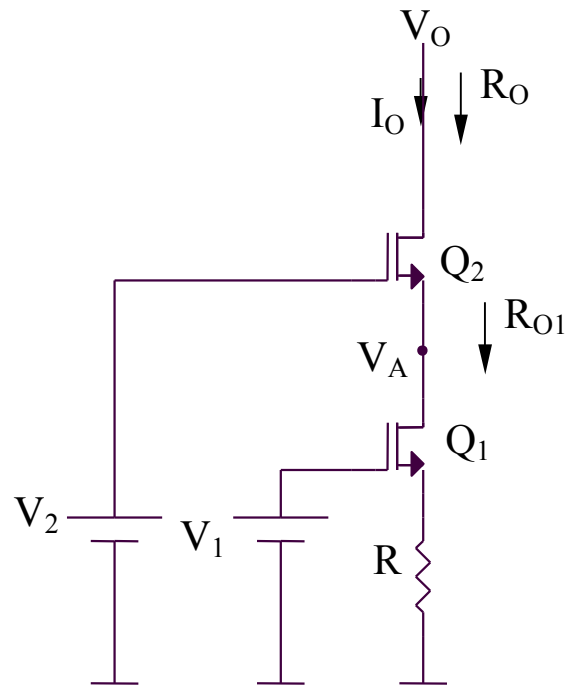

Curentul de iesire

$$\left. \begin{aligned} V_1 &= V_{GS1} + I_O R \\ I_O &= \frac{K}{2} (V_{GS1} - V_T)^2 \end{aligned} \right\} \Rightarrow V_1 = V_{GS1} + \frac{KR}{2} (V_{GS1} - V_T)^2$$

$$\Rightarrow V_{GS1} (> V_T) \Rightarrow I_O$$

Rezistenta de iesire

$$R_O = r_{ds2} (1 + g_m R_{O1}) \cong g_m^2 r_{ds}^2 R$$

$$R_{O1} = r_{ds1} (1 + g_m R)$$

Tensiunea minima de iesire

$$V_{Omin} = V_2 - V_{GS2} + (V_{GS2} - V_T) = V_2 - V_T$$

Este necesar ca:

$$V_{DS1} > V_{DS1sat} \Leftrightarrow$$

$$\Leftrightarrow (V_2 - V_{GS2}) - (V_1 - V_{GS1}) > V_{DS1sat} \Leftrightarrow$$

$$\Leftrightarrow V_2 - V_1 > V_{DS1sat} = V_{GS} - V_T = \sqrt{\frac{2I_O}{K}}$$

Oglinda de curent cascod CMOS (2)

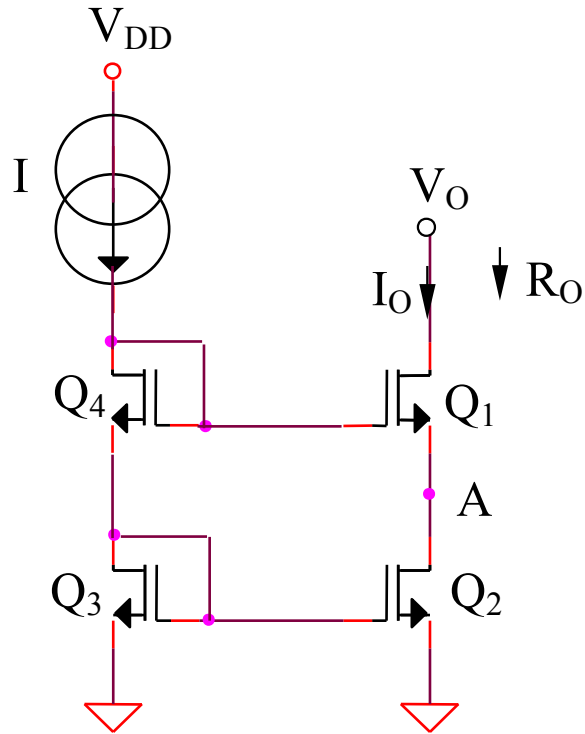

Curentul de iesire

$$\frac{I_O}{I} = \frac{1 + \lambda V_{DS2}}{1 + \lambda V_{DS3}}$$

Rezistenta de iesire

$$R_O = r_{ds1} (1 + g_{m1} r_{ds2}) \cong g_{m1} r_{ds2}^2$$

Tensiunea minima de iesire

$$V_{O\min} = V_A + V_{DS1\text{sat}} = V_{GS} + (V_{GS} - V_T)$$

$$V_{O\min} = 2V_{GS} - V_T \cong V_T + 2\sqrt{\frac{2I}{K}}$$

SIMULARI pentru oglinda de curent CMOS cascod
Caracteristica de iesire

SIMULARI pentru oglinda de curent CMOS cascod

Caracteristica de iesire

SIM 3.7: I_{D2} (V2)

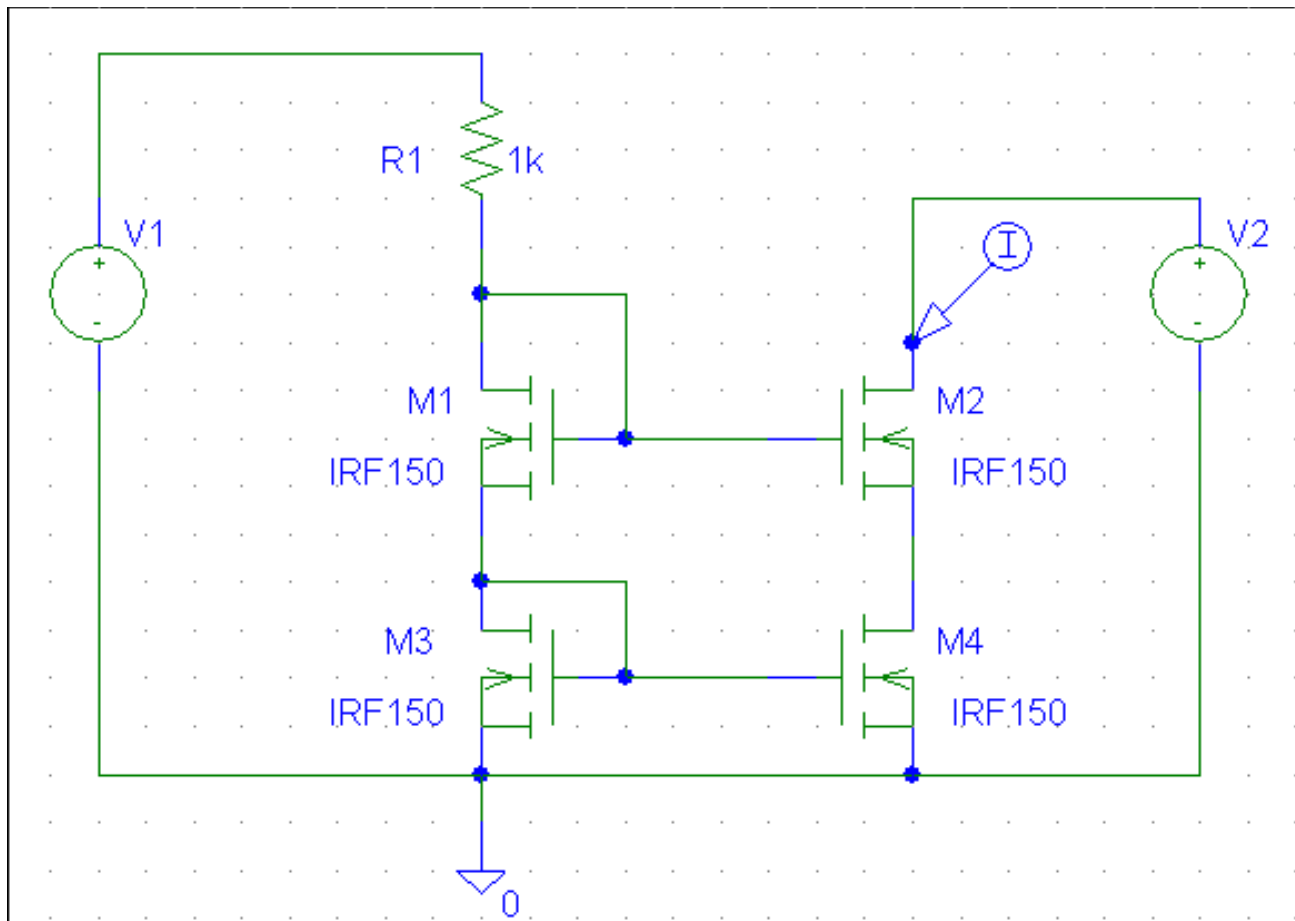

SIMULARI pentru oglinda de curent CMOS cascod

Caracteristica de iesire

SIM 3.8: I_{D2} (V2), r_{ds2} , r_{ds4} - parametri

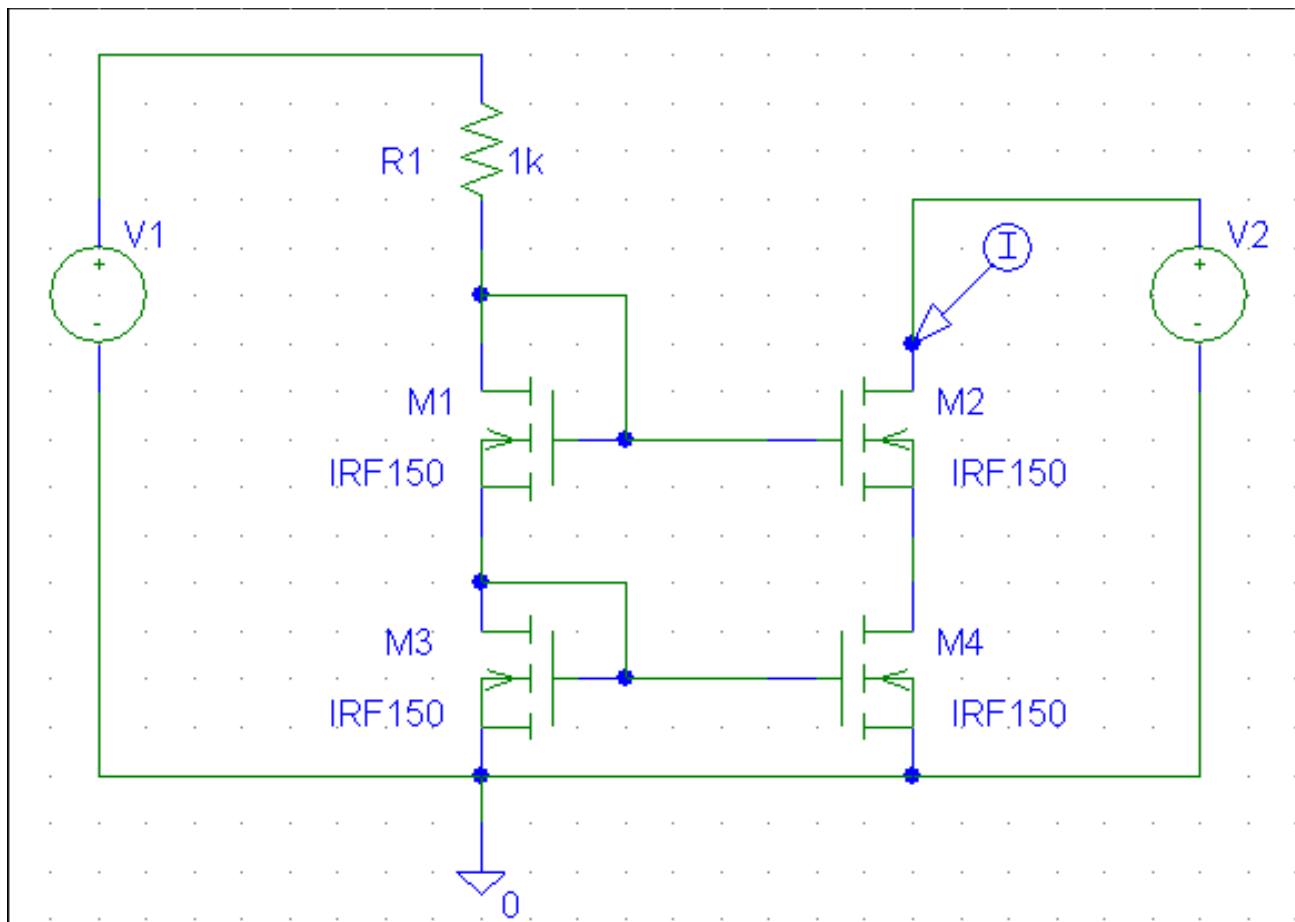

SIMULARI pentru oglinda de curent CMOS cascod
Dependentă curentului de ieșire de tensiunea de alimentare

SIMULARI pentru oglinda de curent CMOS cascod Dependenta curentului de iesire de tensiunea de alimentare

SIM 3.9: I_{D2} (V1)

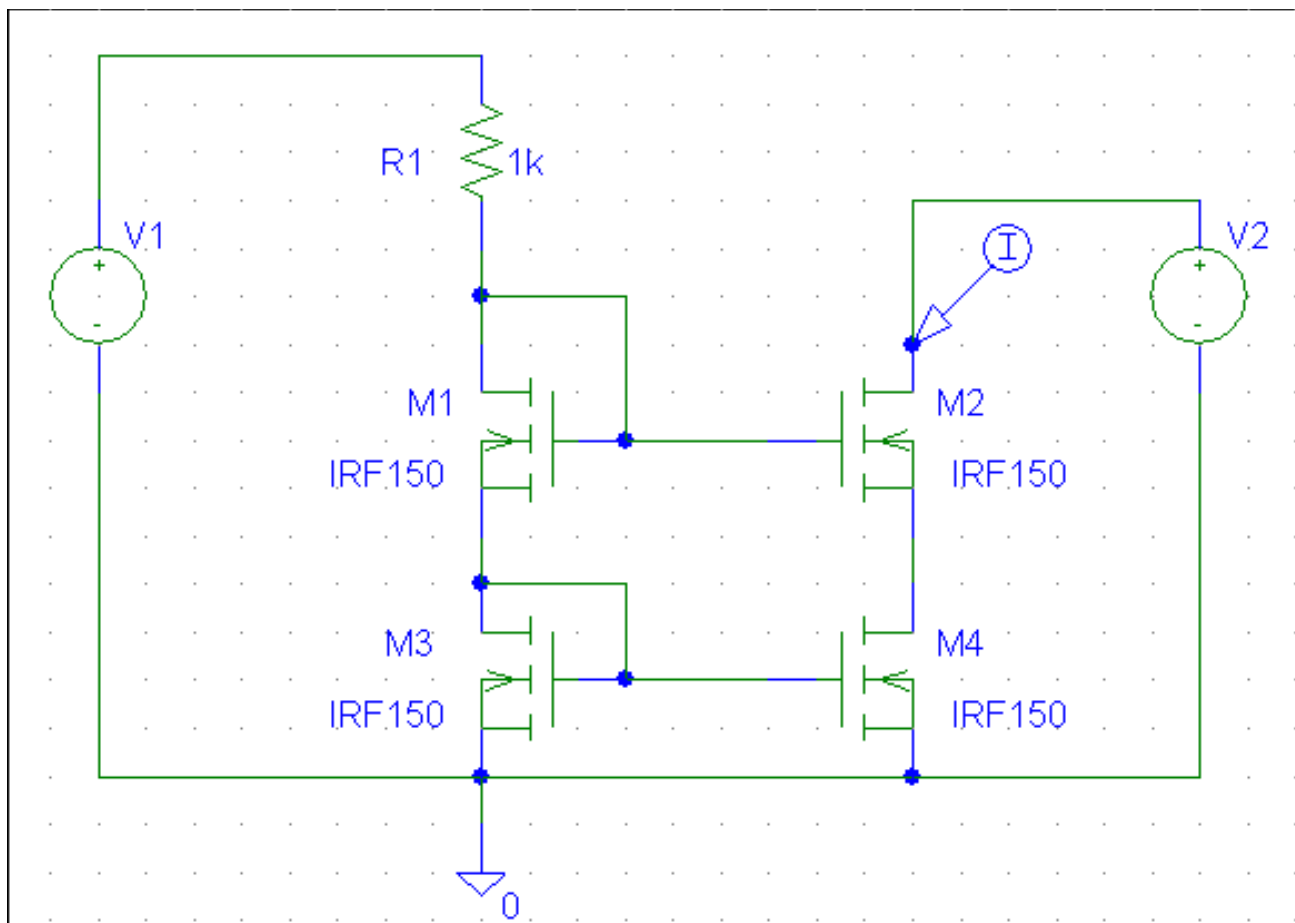

Sursa de curent cascod bipolară (1)

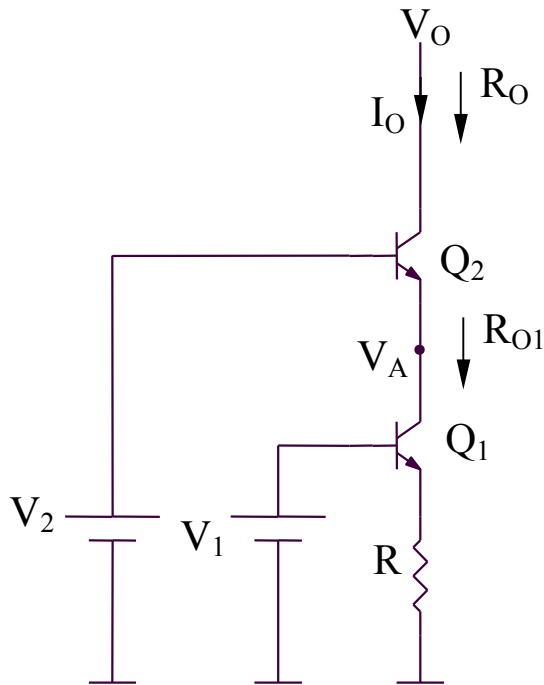

Curentul de iesire

$$I_O = \frac{V_1 - V_{BE1}}{R}$$

Rezistenta de iesire

$$R_O = r_{o2} \left(1 + \frac{\beta R_{O1}}{r_{\pi 2} + R_{O1}} \right) \cong \beta r_{o2}$$

$$R_{O1} = r_{o1} \left(1 + \frac{\beta R}{r_{\pi 1} + R} \right) \gg r_{\pi 2}$$

Tensiune minima de iesire

$$V_{O \min} = V_A + V_{CE2 \text{ sat}} = V_2 - V_{BE2} + V_{CE2 \text{ sat}}$$

Este necesar ca:

$$V_{CE1} > V_{CE1 \text{ sat}} \Leftrightarrow$$

$$\Leftrightarrow (V_2 - V_{BE2}) - (V_1 - V_{BE1}) > V_{CE1 \text{ sat}} \Leftrightarrow$$

$$\Leftrightarrow V_2 - V_1 > V_{CE1 \text{ sat}}$$

Oglinda de curent cascod bipolară (2)

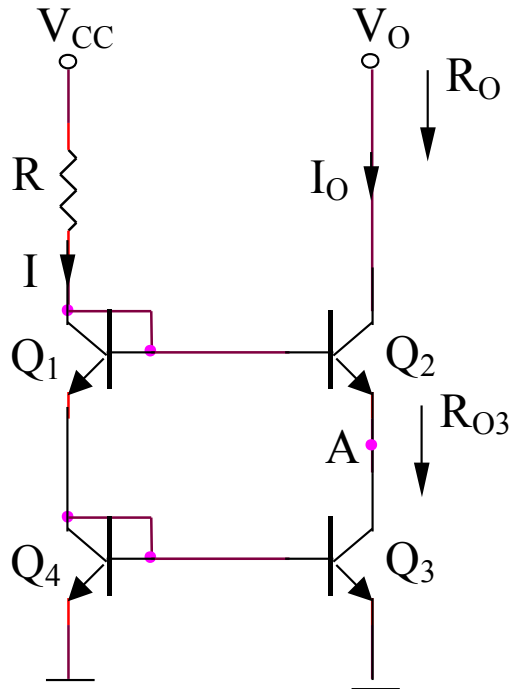

Curentul de iesire

$$I_O = I = \frac{V_{CC} - 2v_{BE}}{R}$$

Rezistenta de iesire

$$R_O = r_{o2} \left(1 + \beta \frac{R_{O3}}{r_{\pi 2} + R_{O3} + R // (2 / g_{m1})} \right)$$

$$R_{O3} = r_{o3} \gg r_{\pi 2}, R // (2 / g_{m1})$$

Deci:

$$R_O \cong \beta r_{o2}$$

Tensiunea minima de iesire

$$V_{O \min} = V_A + V_{CE2 \text{ sat}}$$

$$V_A = v_{BE1} + v_{BE4} - v_{BE2} = v_{BE}$$

Sursa de curent cascod bipolară (3)

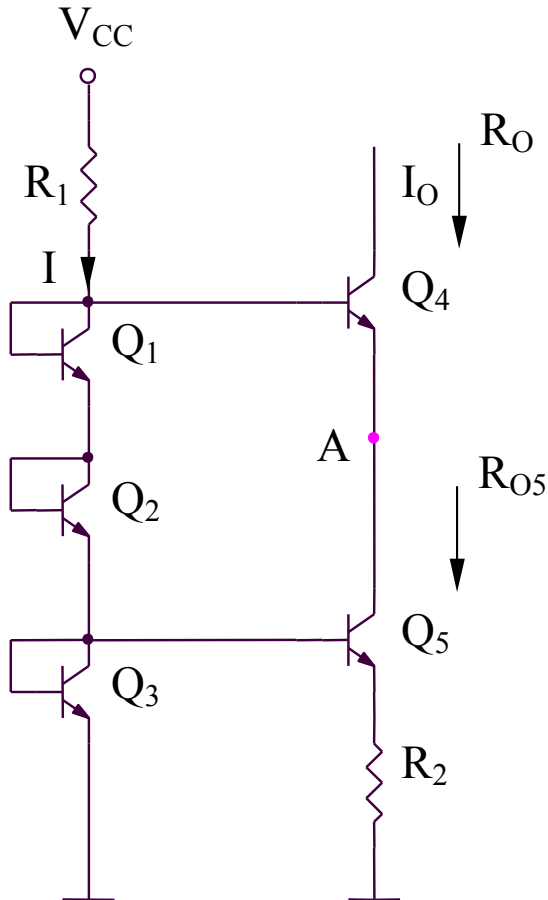

Curentul de iesire

$$I_O = \frac{v_{BE3} - v_{BE5}}{R_2} = \frac{V_{th}}{R_2} \ln\left(\frac{I}{I_O}\right)$$

$$I = \frac{V_{CC} - 3v_{BE}}{R_1}$$

Rezistenta de iesire

$$R_O = r_{o4} \left(1 + \beta \frac{R_{O5}}{r_{\pi4} + R_{O5} + R_1 // (3 / g_{m1})} \right)$$

$$R_{O5} \cong r_{o5} \left(1 + \frac{\beta R_2}{r_{\pi5} + R_2 + 1 / g_{m3}} \right)$$

$$R_{O5} \gg r_{\pi4}, R_1 // (3 / g_{m1})$$

Deci:

$$R_O \cong \beta r_{o4}$$

Tensiunea minima de iesire

$$V_{Omin} = V_A + V_{CE4sat}$$

$$V_A = 2v_{BE}$$

Sursa de curent cascod MOS (3)

Curentul de iesire

$$I_O = I$$

Rezistenta de iesire

$$R_O = r_{ds1} (1 + g_{m1} r_{ds2}) \cong g_m r_{ds}^2$$

Tensiunea minima de iesire

$$I = \frac{K'}{2} \frac{W/L}{(n+1)^2} (V_{GS5} - V_T)^2$$

$$I = \frac{K'}{2} \frac{W/L}{n^2} (V_{GS1(4)} - V_T)^2$$

$$I = \frac{K'}{2} (W/L) (V_{GS2(3)} - V_T)^2$$

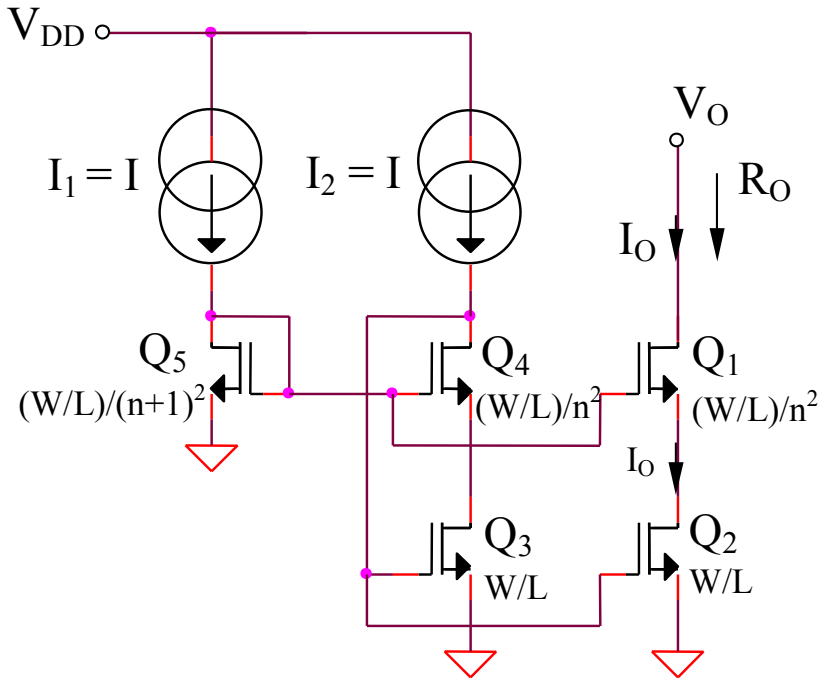

$$\Rightarrow \begin{cases} V_{GS5} - V_T = (n+1)(V_{GS2(3)} - V_T) \\ V_{GS1(4)} - V_T = n(V_{GS2(3)} - V_T) \end{cases}$$

Tensiunea drena-sursa a tranzistorului Q_2 este:

$$V_{DS2} = V_{GS5} - V_{GS1} = (V_{GS5} - V_T) - (V_{GS1} - V_T) = V_{GS2} - V_T = V_{DS2sat}$$

Deci, Q_2 este polarizat la limita de saturatie. Rezulta:

$$V_{Omin} = V_{DS1sat} + V_{DS2} = (n+1)(V_{GS2} - V_T) = (n+1)\sqrt{\frac{2I}{K}}$$

3.1.4. Surse de curent cu autopolarizare

3.1.4. Surse de curent cu autopolarizare

Oglinda de curent

$$I_O = \frac{V_{CC} - v_{BE}}{R}$$

$$S_{V_{CC}}^{I_O} = \frac{V_{CC}}{I_O} \frac{\partial I_O}{\partial V_{CC}} \cong 1$$

Sursa de curent Widlar bipolară

$$I_O = \frac{V_{th}}{R_2} \ln \frac{I}{I_O}$$

$$\frac{\partial I_O}{\partial V_{CC}} = \frac{V_{th}}{R_2} \frac{I_O}{I} \left(\frac{1}{I_O} \frac{\partial I}{\partial V_{CC}} - \frac{I}{I_O^2} \frac{\partial I_O}{\partial V_{CC}} \right)$$

$$\frac{\partial I_O}{\partial V_{CC}} = \frac{\frac{V_{th}}{IR_2}}{1 + \frac{V_{th}}{R_2 I_O}} \frac{\partial I}{\partial V_{CC}}$$

$$S_{V_{CC}}^{I_O} = \frac{V_{CC}}{I_O} \frac{\partial I_O}{\partial V_{CC}} = \frac{V_{CC}}{I} \frac{1}{1 + \frac{R_2 I_O}{V_{th}}} \frac{\partial I}{\partial V_{CC}} \cong \frac{1}{1 + \frac{R_2 I_O}{V_{th}}}$$

Sursa de curent utilizand ca referinta tensiunea baza-emitor

$$I_O = \frac{V_{th}}{R_2} \ln \frac{V_{CC} - 2v_{BE}}{R_1 I_S}$$

$$\frac{\partial I_O}{\partial V_{CC}} \cong \frac{V_{th}}{R_2} \frac{R_1 I_S}{V_{CC} - 2v_{BE}} \frac{1}{R_1 I_S}$$

$$S_{V_{CC}}^{I_O} \cong \frac{V_{th}}{v_{BE}} \cong 4\%$$

Sursa de curent cu autopolarizare utilizand ca referinta tensiunea baza-emitor

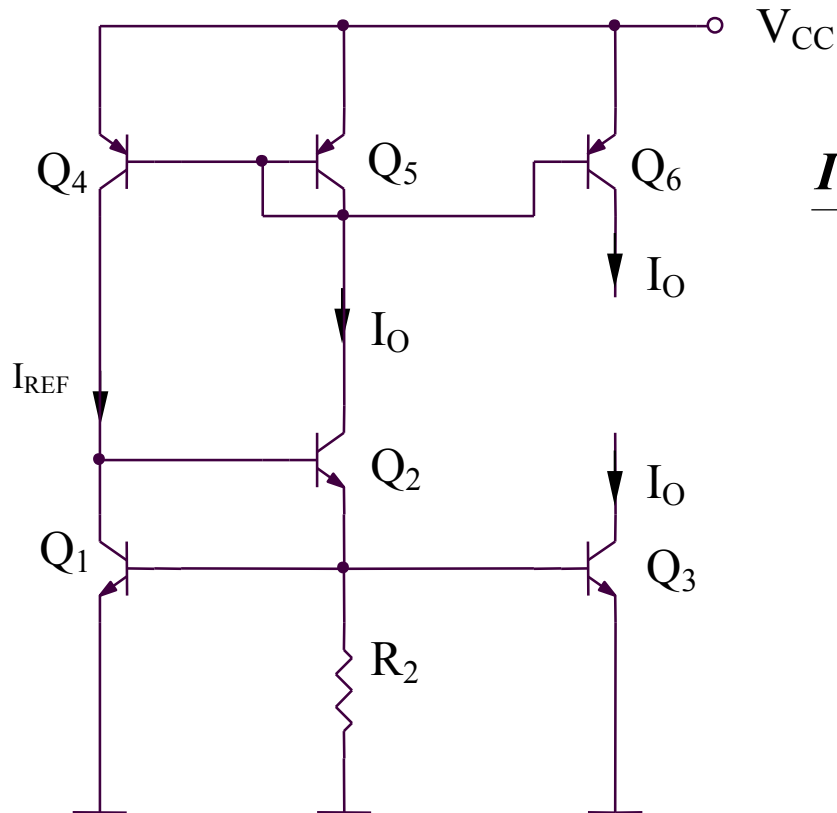

$$I_O = \frac{v_{BE1}}{R_2} = \frac{V_{th}}{R_2} \ln \frac{I_{REF}}{I_S}$$

$$\frac{I_{REF}}{I_O} = \frac{1 + \frac{V_{CC} - 2v_{BE}}{V_A}}{1 + \frac{v_{BE}}{V_A}} \approx 1 + \frac{V_{CC} - 2v_{BE}}{V_A}$$

$$\Rightarrow I_O = \frac{V_{th}}{R_2} \ln \frac{I_O}{I_S} + \frac{V_{th}}{R_2} \ln \left(1 + \frac{V_{CC} - 2v_{BE}}{V_A} \right)$$

Derivand:

$$\frac{\partial I_O}{\partial V_{CC}} = \frac{V_{th}}{R_2(V_A + V_{CC})}$$

rezulta:

$$S_{V_{CC}}^{I_O} \approx \frac{V_{th}}{v_{BE}} \frac{1}{1 + \frac{V_A}{V_{CC}}}$$

Sursa de curent Widlar cu autopolarizare

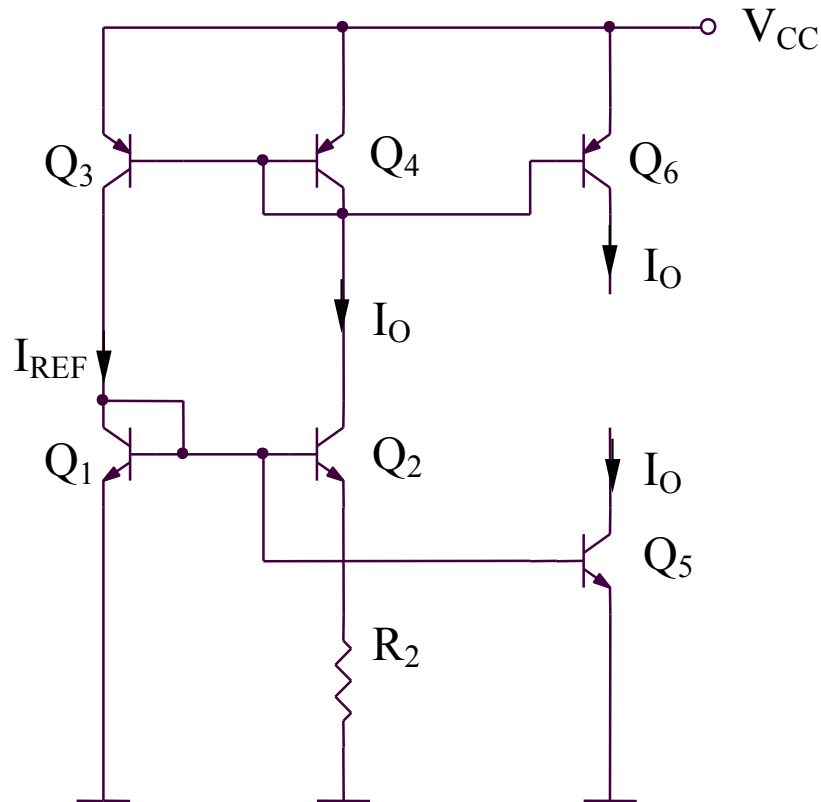

$$I_O = \frac{v_{BE1} - v_{BE2}}{R_2}$$

$$I_O = \frac{V_{th}}{R_2} \ln\left(\frac{I_{REF}}{I_O}\right) + \frac{V_{th}}{R_2} \ln\left(\frac{I_{S2}}{I_{S1}}\right)$$

$$I_O \cong \frac{V_{th}}{R_2} \ln\left(1 + \frac{V_{CC}}{V_A}\right) + \frac{V_{th}}{R_2} \ln\left(\frac{I_{S2}}{I_{S1}}\right)$$

$$S_{V_{CC}}^{I_O} \cong \frac{V_{CC}}{V_A} \frac{1}{\ln\left(\frac{I_{S2}}{I_{S1}}\right)}$$

Sursa de curent CMOS cu autopolarizare (1)

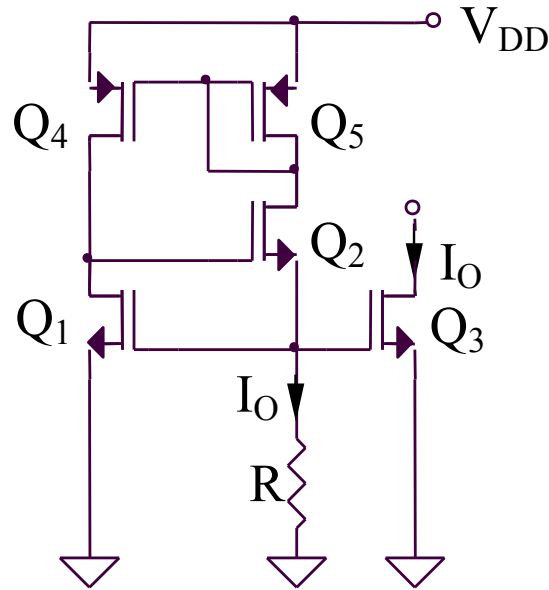

Curentul de iesire

$$I_O = \frac{V_{GS}}{R} = \frac{K}{2} (V_{GS} - V_T)^2$$

$$\frac{KR}{2} V_{GS}^2 - (1 + KR V_T) V_{GS} + \frac{KR}{2} V_T^2 = 0$$

Rezolvand ecuatia pentru V_{GS} rezulta:

$$V_{GS1,2} = V_T + \frac{1}{KR} \pm \frac{\sqrt{2KR V_T + 1}}{KR}$$

$$V_{GS} = V_T + \frac{1}{KR} + \frac{\sqrt{2KR V_T + 1}}{KR}$$

Deci:

$$I_O = \frac{1}{KR^2} \left(1 + KR V_T + \sqrt{1 + 2KR V_T} \right)$$

Sursa de curent CMOS cu autopolarizare (2)

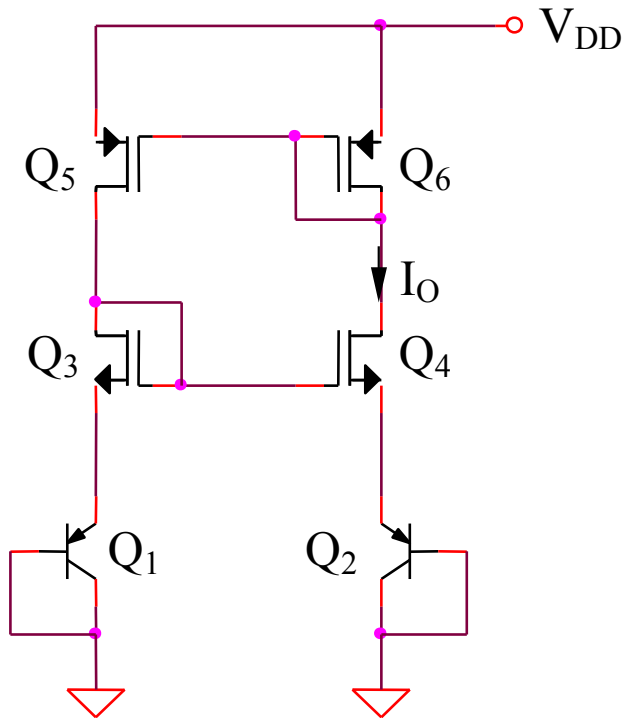

Curentul de iesire

$$V_T + \sqrt{\frac{2I_O}{4K}} + V_{th} \ln\left(\frac{I_O}{I_S}\right) =$$

$$= V_T + \sqrt{\frac{2I_O}{K}} + V_{th} \ln\left(\frac{I_O}{10I_S}\right)$$

Rezulta:

$$I_O = 2K[V_{th} \ln(10)]^2$$

$$V_{th} = \frac{kT}{q} - \text{tensiunea termica}$$

Sursa de curent CMOS cu autopolarizare (3)

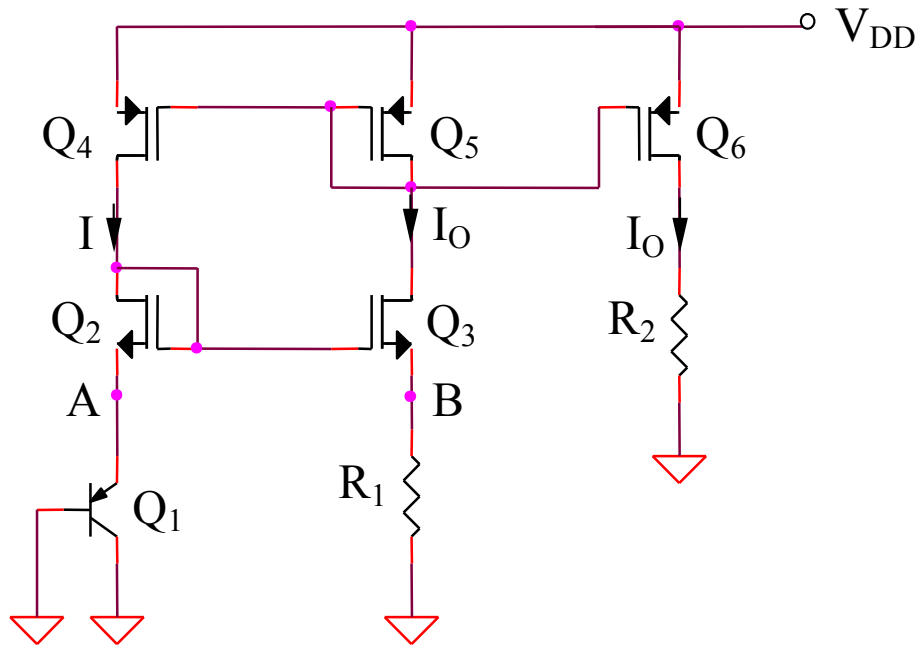

Curentul de iesire

Pentru tranzistoare MOS identice,
 $V_A = V_B$, deci:

$$I_O = \frac{V_{EB1}}{R_1}$$

SIMULARI pentru sursa de curent CMOS cu autopolarizare (3)
Dependenta curentului de iesire de tensiunea de alimentare

SIMULARI pentru sursa de curent CMOS cu autopolarizare (3)

Dependenta curentului de iesire de tensiunea de alimentare

SIM 3.10: I_{D2} (V1)

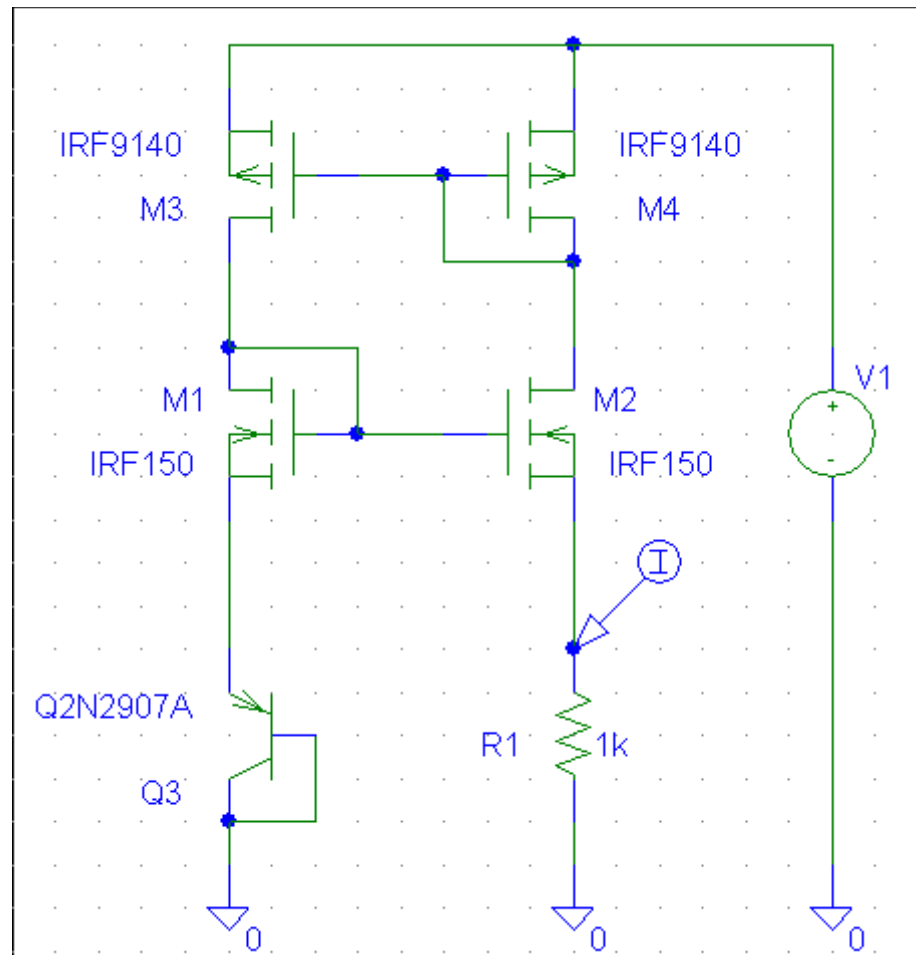

SIMULARI pentru sursa de curent CMOS cu autopolarizare (3)
Dependenta curentului de iesire de temperatura

SIMULARI pentru sursa de curent CMOS cu autopolarizare (3)

Dependenta curentului de iesire de temperatura

SIM 3.11: $I_{D2}(t)$

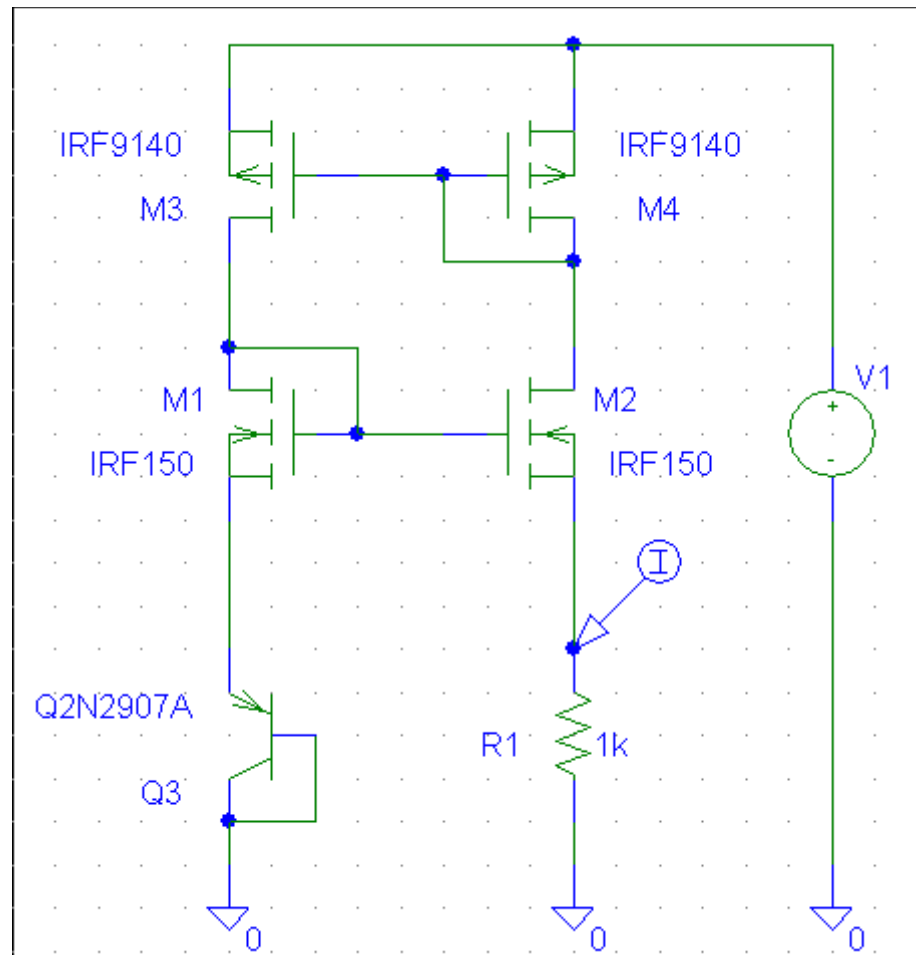

Sursa de curent CMOS cu autopolarizare (4)

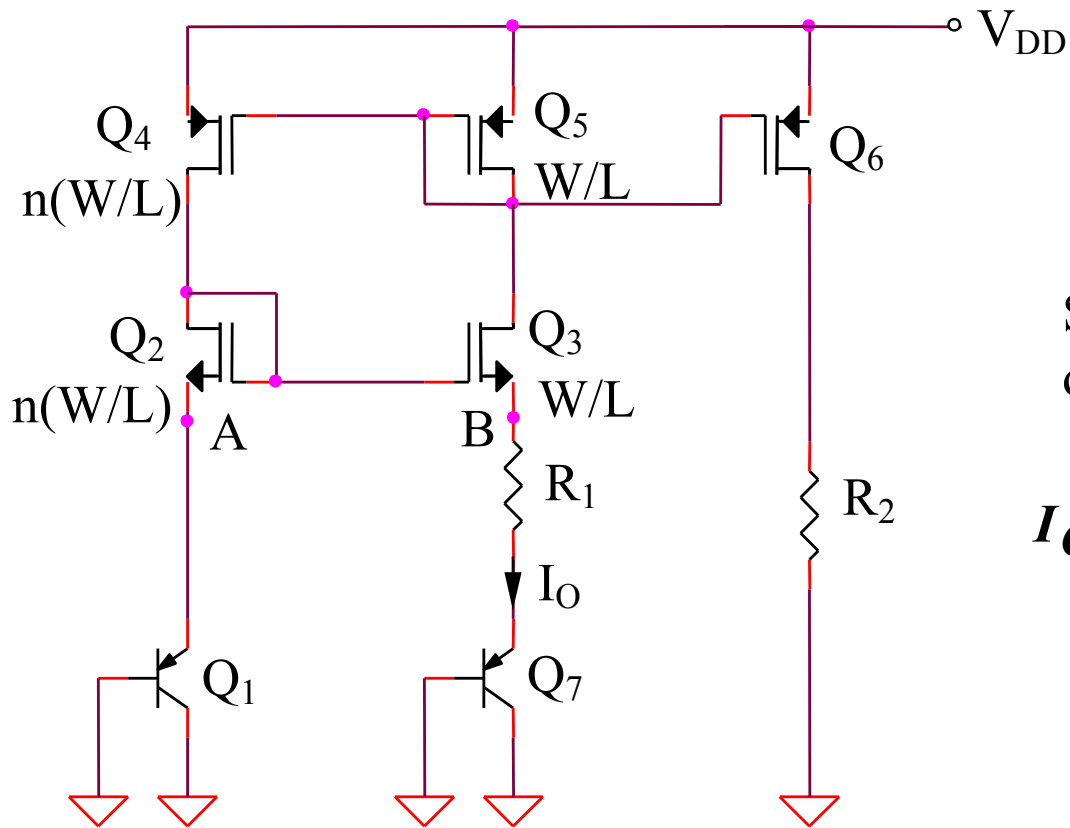

Curentul de iesire

Se poate demonstra ca $V_A = V_B$,
deci:

$$I_O = \frac{|V_{BE1}| - |V_{BE7}|}{R_1} = \frac{V_{th}}{R_1} \ln(n)$$

Sursa de curent CMOS cu autopolarizare (5)

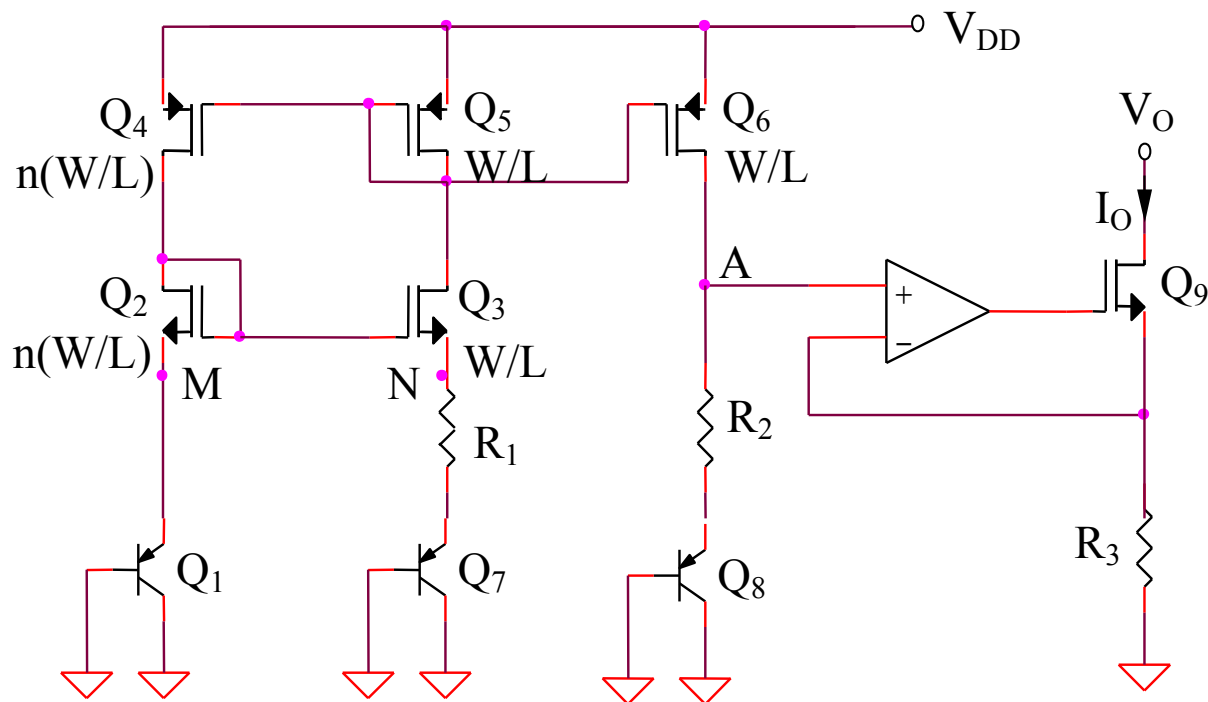

$$\left. \begin{aligned} V_{GS2} &= V_{GS3} \\ V_{R2} &= R_2 \frac{V_{EB1} - V_{EB7}}{R_1} = \frac{R_2}{R_1} V_{th} \ln(n) \end{aligned} \right\} \Rightarrow I_O(T) = \frac{I}{R_3} \left[\frac{R_2}{R_1} V_{th} \ln(n) + V_{EB8}(T) \right]$$

$$V_{EB}(T) = A + BT + CT \ln\left(\frac{T}{T_O}\right)$$

Sursa de curent CMOS cu autopolarizare (5) – cont.

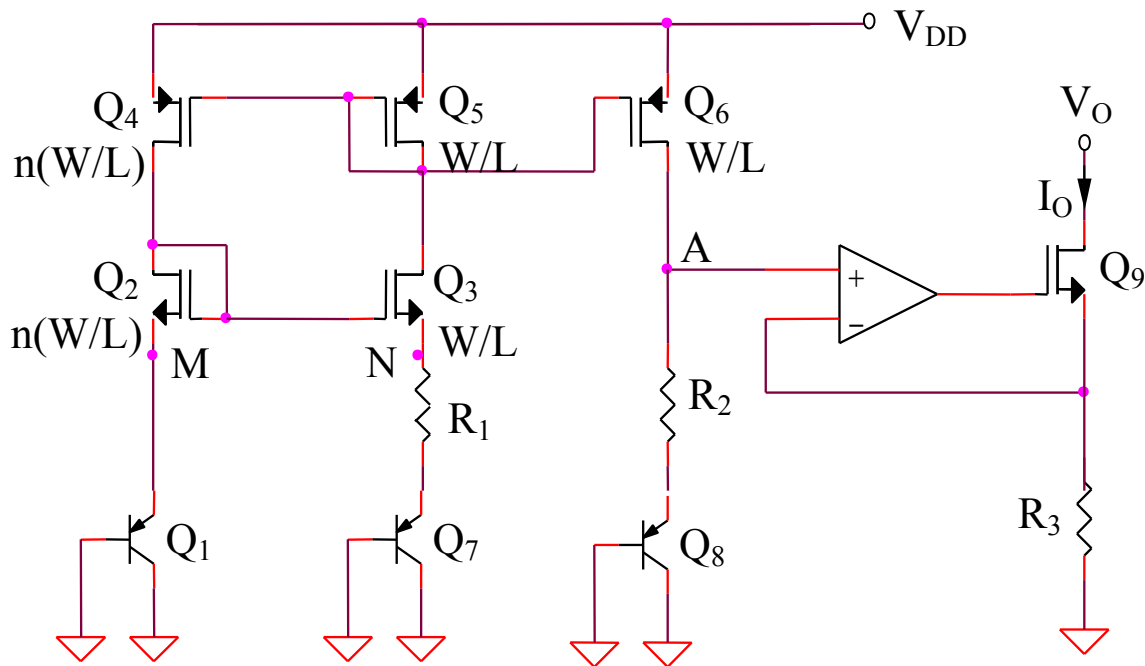

$$\Rightarrow I_O(T) = \frac{I}{R_3} \left[\frac{R_2}{R_1} \frac{kT}{q} \ln(n) + A + BT + CT \ln\left(\frac{T}{T_O}\right) \right]$$

Conditia de corectie liniara a caracteristicii poate fi scrisa astfel:

$$B + \frac{R_2}{R_1} \frac{k}{q} \ln(n) = 0$$

Rezulta:

$$I_O(T) = \frac{I}{R_3} \left[A + CT \ln\left(\frac{T}{T_O}\right) \right]$$

3.2. Surse de tensiune

3.2. Surse de tensiune

3.2.1. Clasificare

I. Surse de tensiune elementare

- complexitate redusa
- performante modeste

II. Surse de tensiune cu reactie

- rezistenta de iesire redusa
- complexitate medie

III. Surse de tensiune compensate cu temperatura

- dependenta redusa de temperatura a tensiunii de iesire
- complexitate ridicata

3.2.2. Surse de tensiune cu reactie

3.2.2. Surse de tensiune cu reactie

Surse de tensiune cu stabilizare serie (schema bloc)

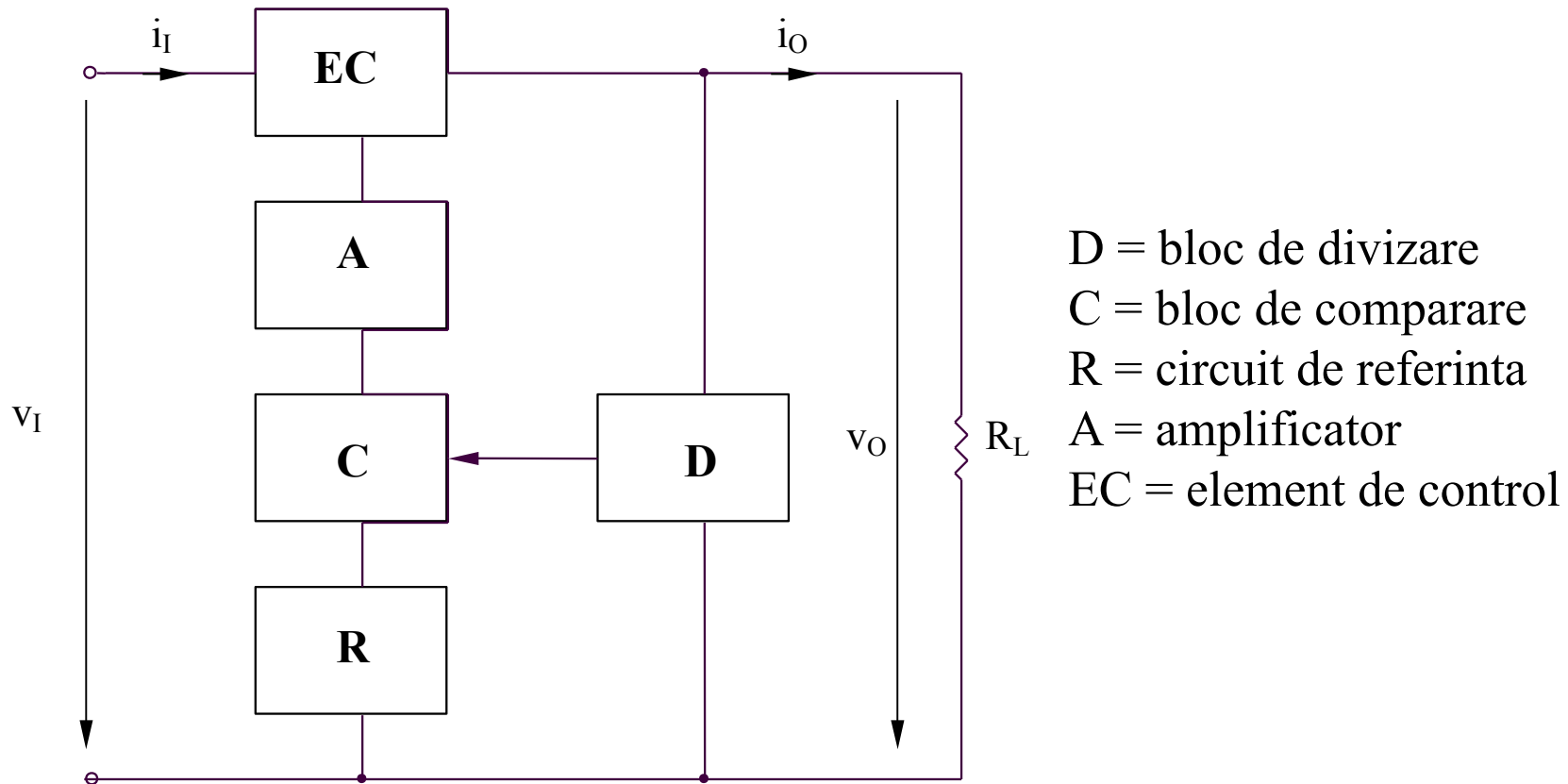

Surse de tensiune cu stabilizare paralel (schema bloc)

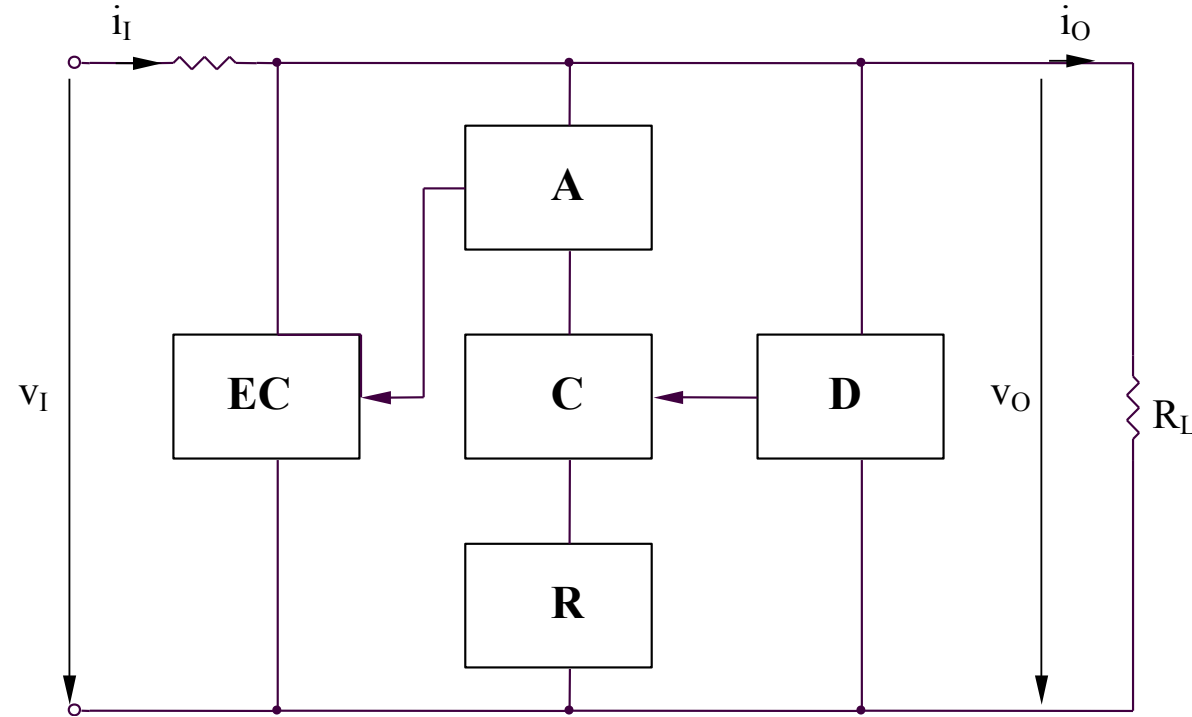

D = bloc de divizare

C = bloc de comparare

R = circuit de referinta

A = amplificator

EC = element de control

Exemple de surse de tensiune

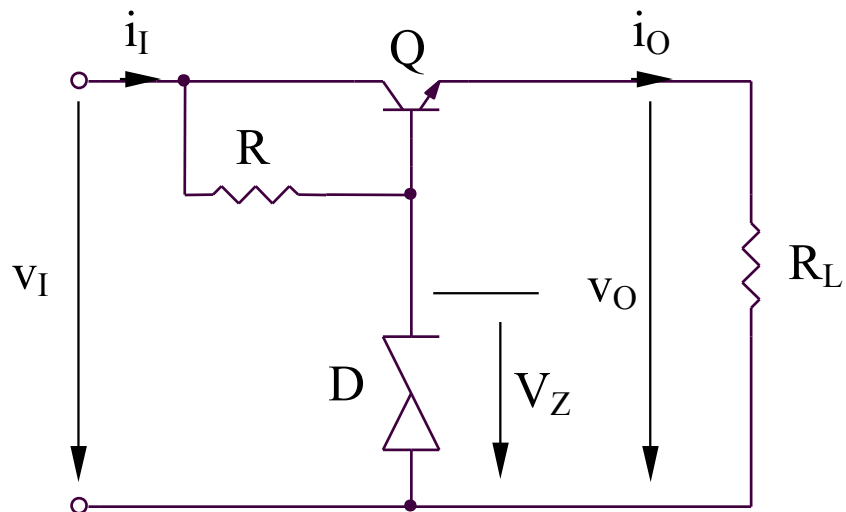

$$v_O = V_Z - V_{BE}$$

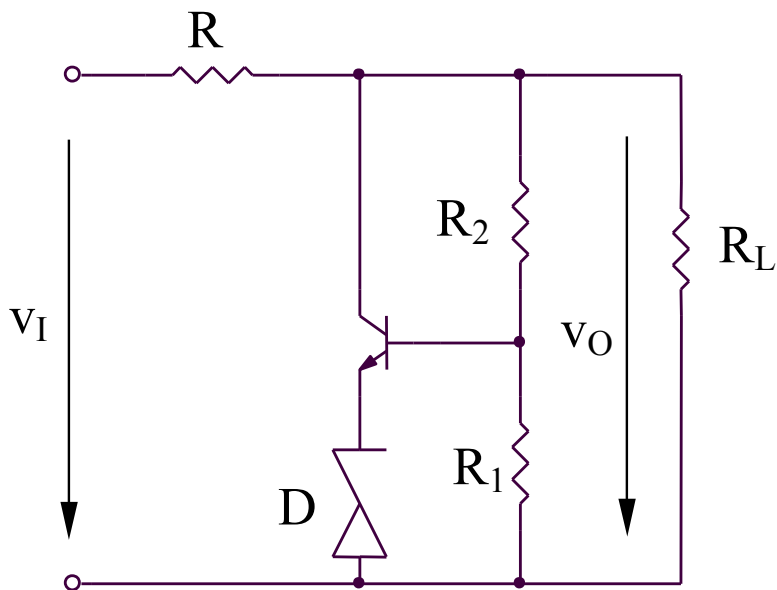

$$v_O = (V_{BE} + V_Z) \left(1 + \frac{R_2}{R_1} \right) > V_Z$$

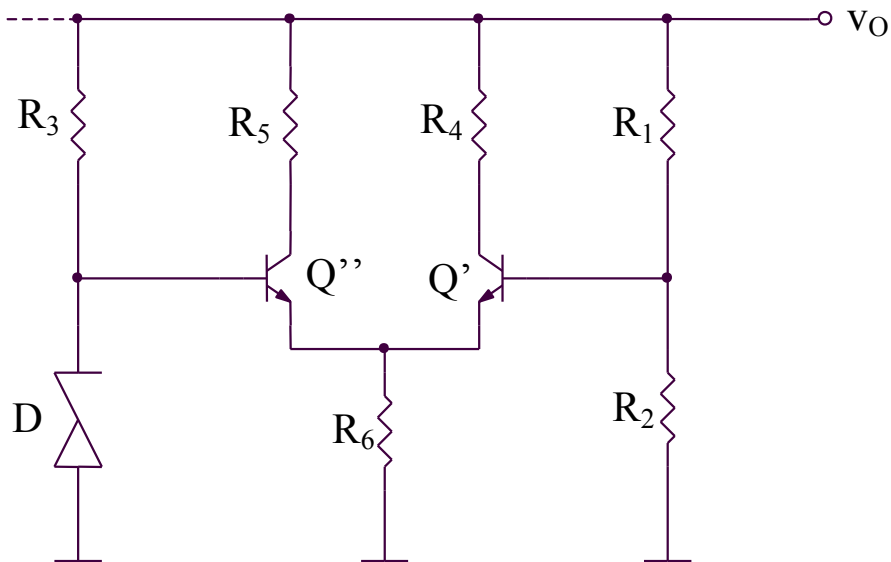

$$v_O = V_Z \left(1 + \frac{R_1}{R_2} \right)$$

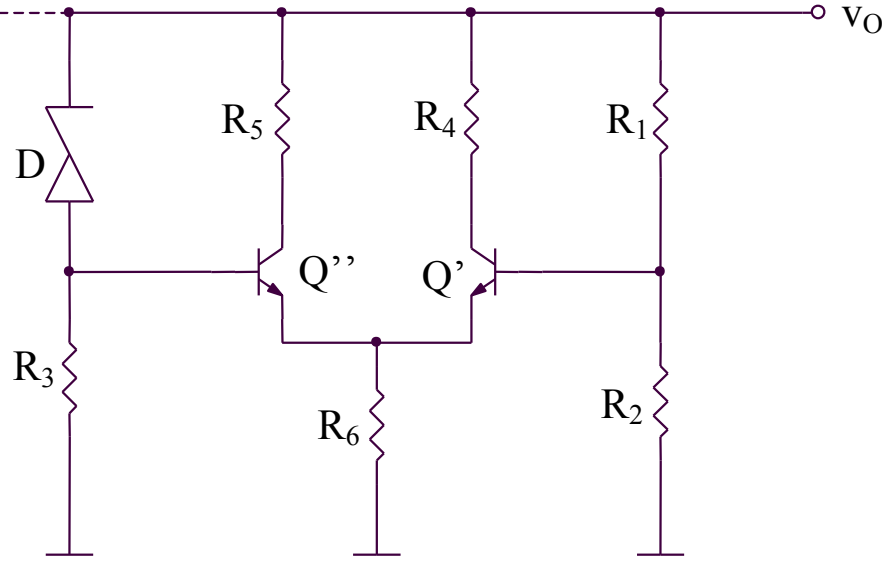

$$v_O = V_Z \left(1 + \frac{R_2}{R_1} \right)$$

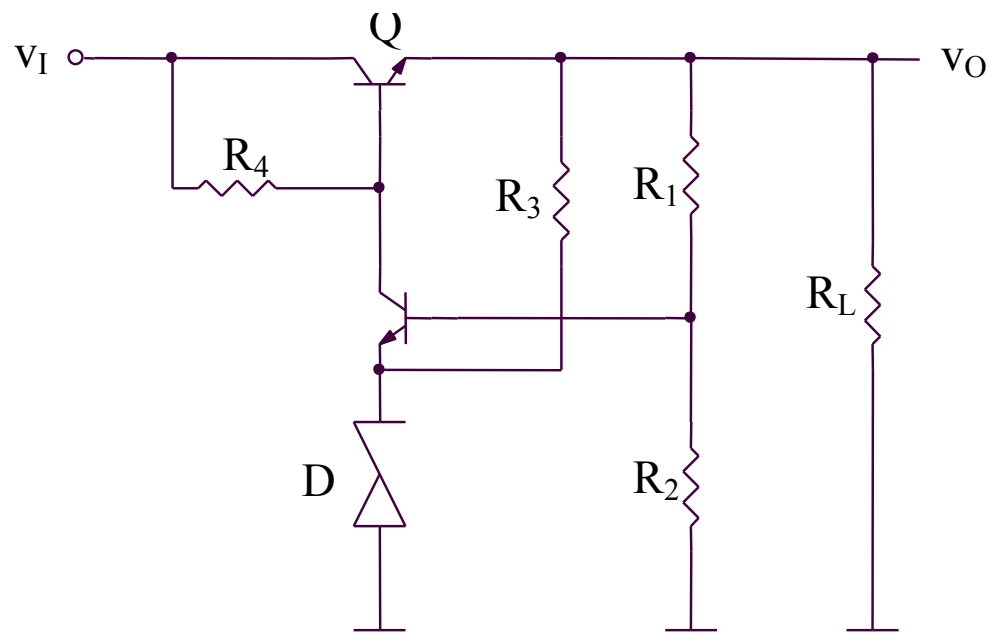

$$v_O = (V_Z + V_{BE}') \left(1 + \frac{R_1}{R_2} \right)$$

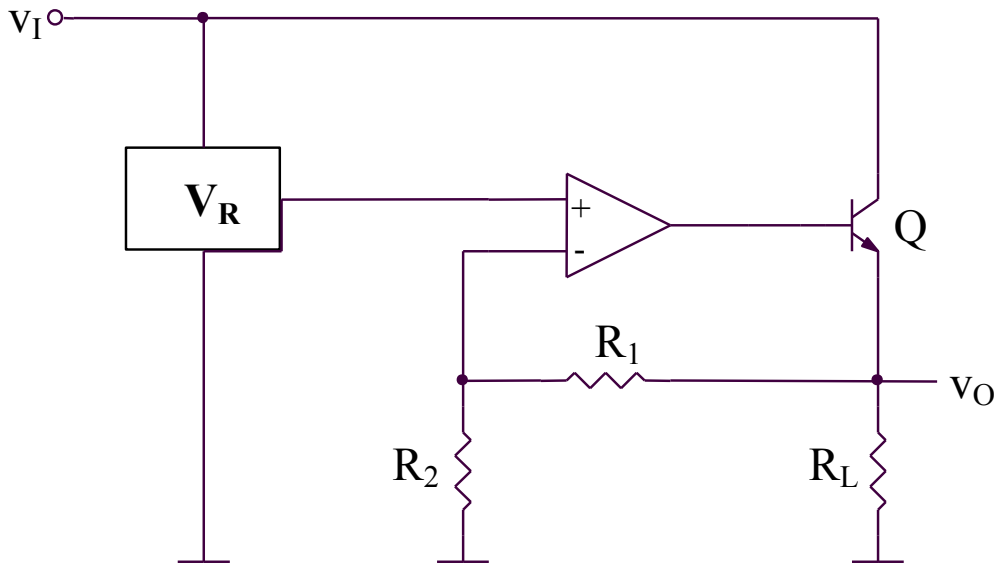

$$V_R = V_O \frac{R_2}{R_1 + R_2}$$

$$V_O = V_R \left(1 + \frac{R_1}{R_2} \right)$$

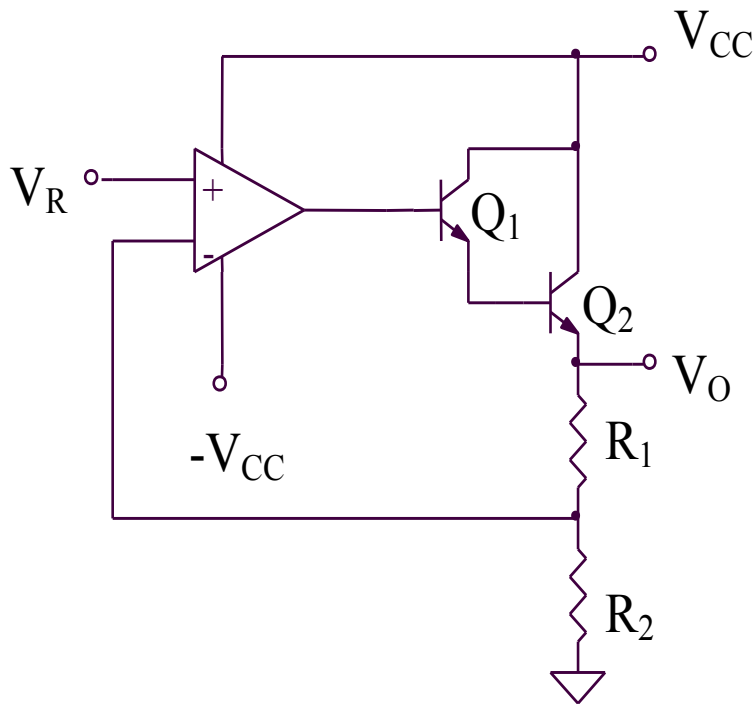

$$V_R = V_O \frac{R_2}{R_1 + R_2}$$

$$V_O = V_R \left(1 + \frac{R_1}{R_2} \right)$$

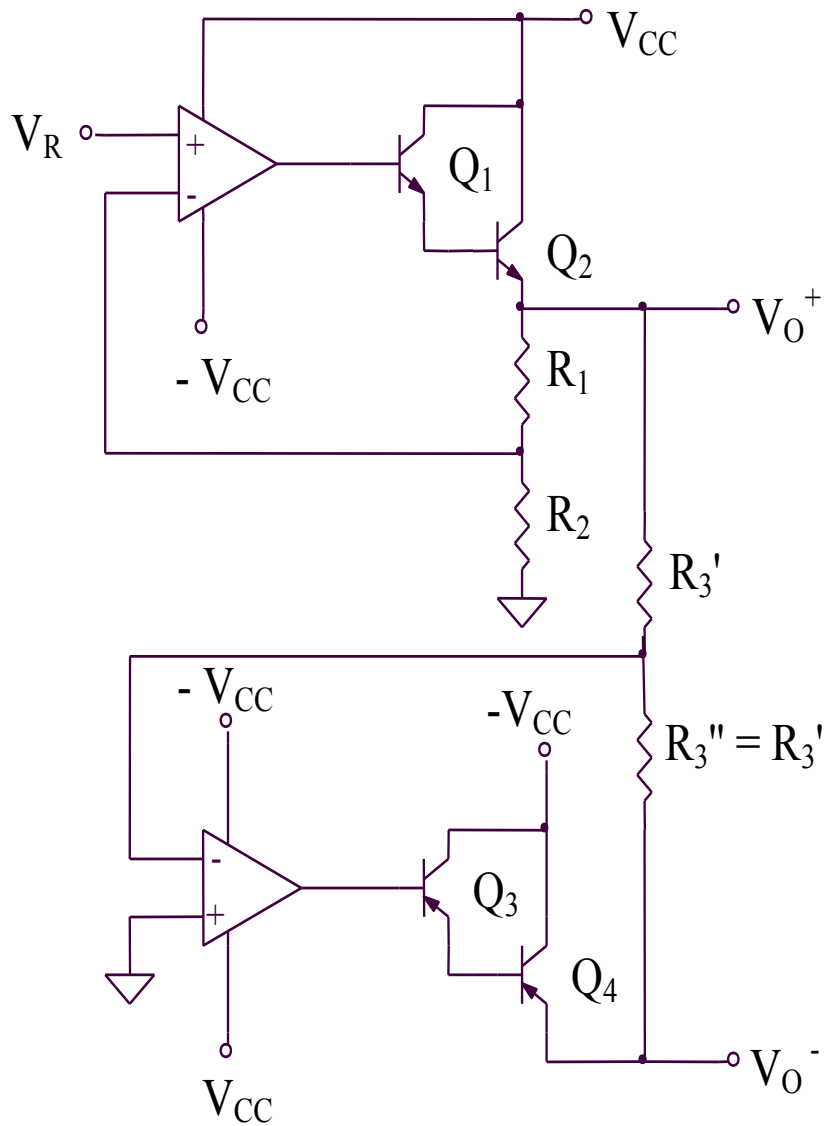

$$V_R = V_O^+ \frac{R_2}{R_1 + R_2}$$

$$V_O^+ = V_R \left(1 + \frac{R_1}{R_2} \right)$$

$$\frac{V_O^+}{R_3'} = -\frac{V_O^-}{R_3''} \Rightarrow V_O^- = -V_O^+$$

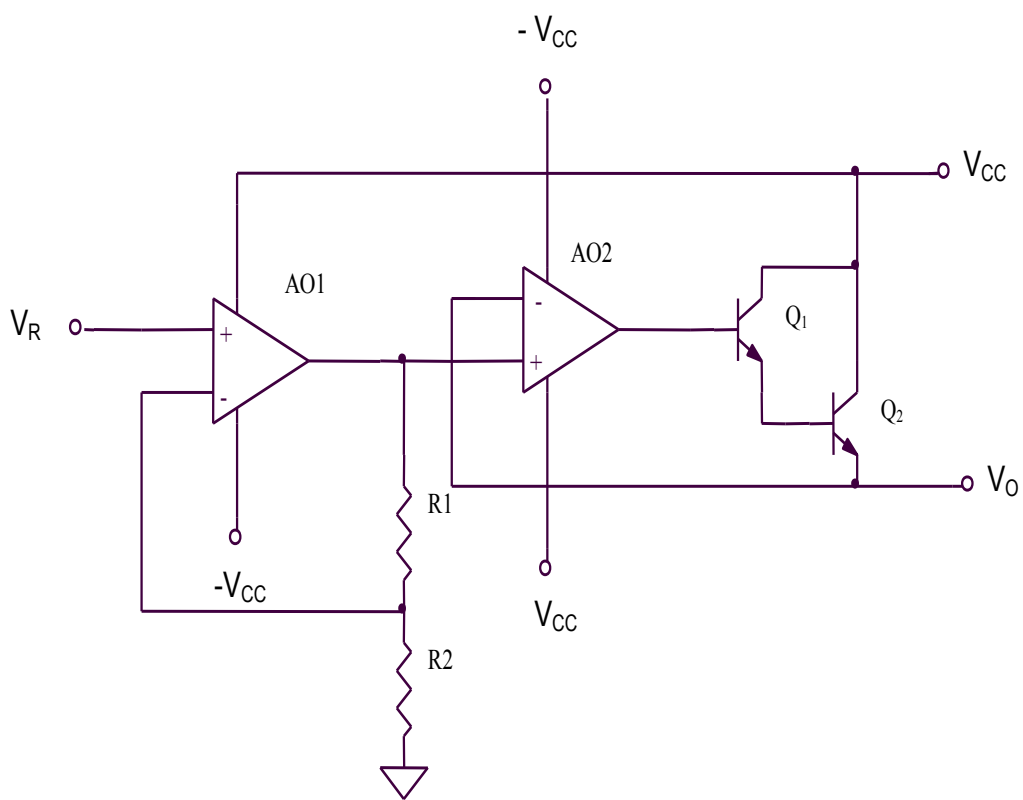

$$V_R = V_O \frac{R_2}{R_1 + R_2}$$

$$V_O = V_R \left(1 + \frac{R_1}{R_2} \right)$$

Protectia la suprasarcina (1)

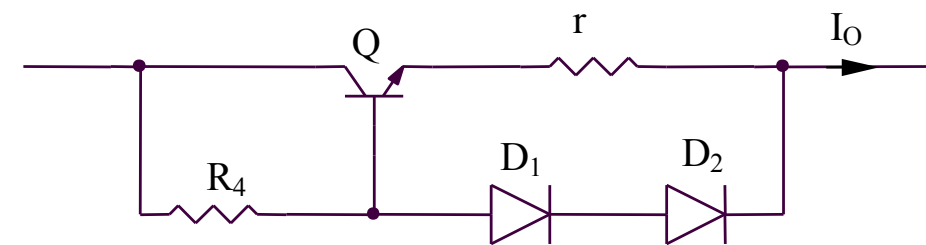

$$I_{OL} = \frac{V_{D1} + V_{D2} - V_{BE}}{r} \cong \frac{V_D}{r}$$

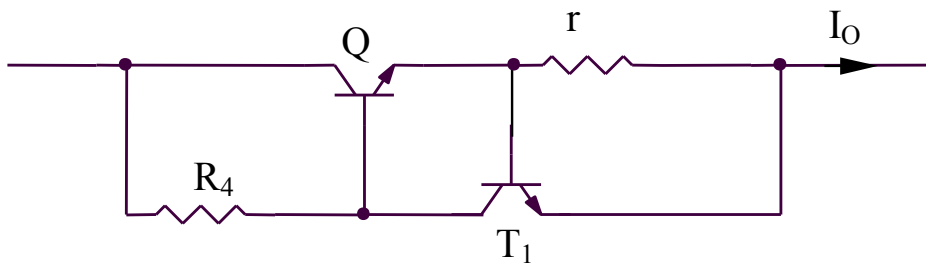

$$I_{OL} = \frac{V_{BE}}{r}$$

Protectia la suprasarcina (2)

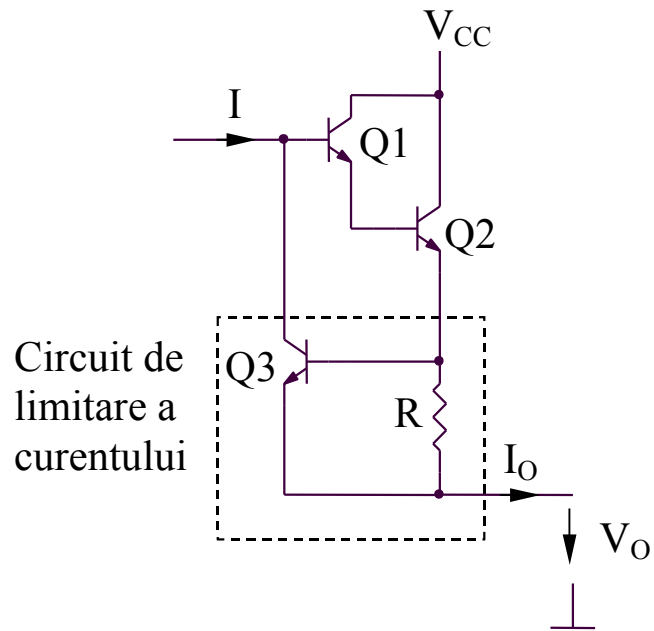

$$I_{OL} = \frac{V_{BE3}}{R}$$

circuitul BA 723

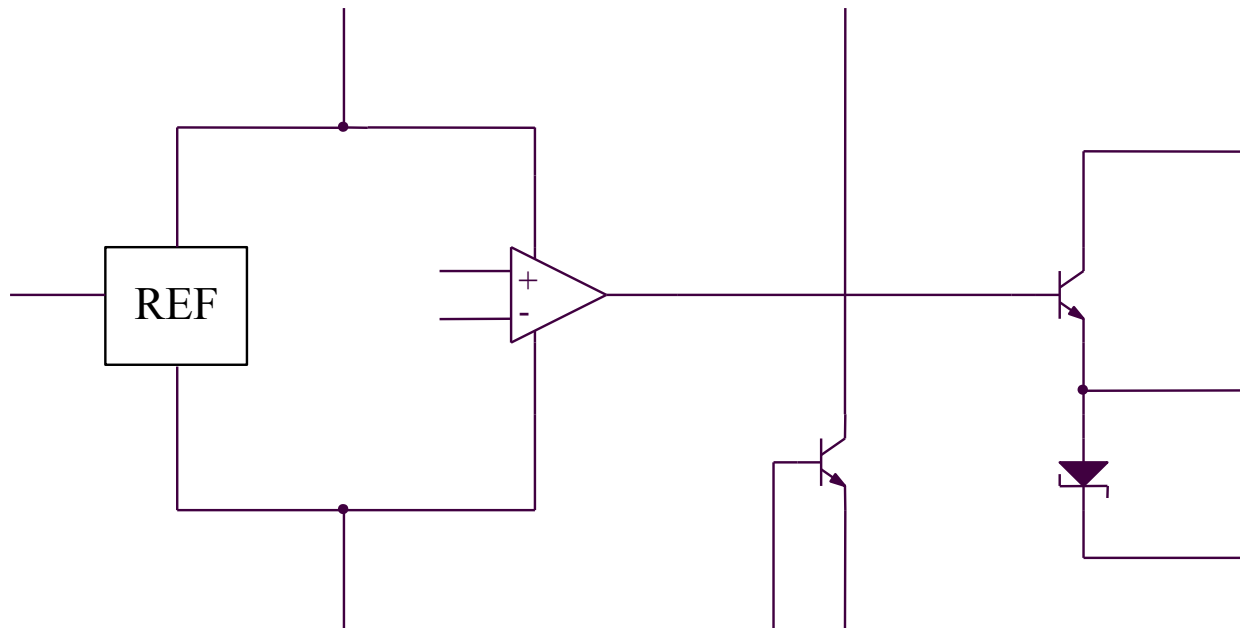

Sursa de tensiune pentru $V_O < V_R$

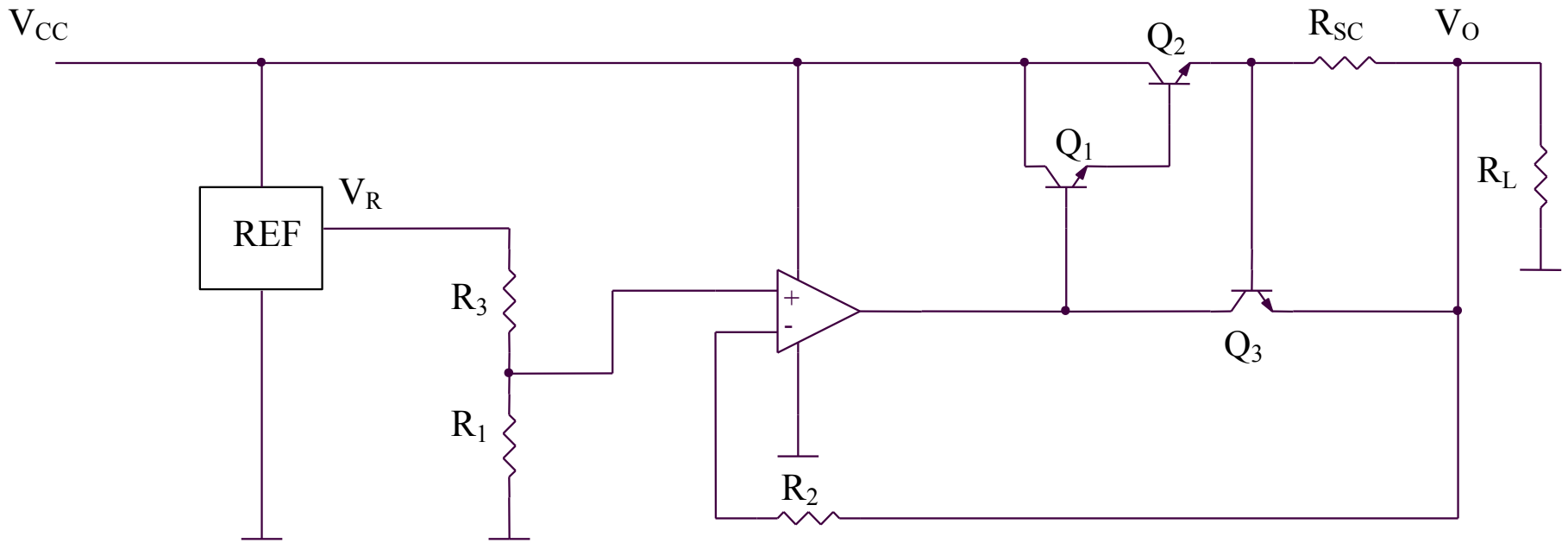

$$V_O = V_R \frac{R_1}{R_1 + R_3} < V_R$$

$$I_{Osc} = \frac{V_{BE}}{R_{sc}}$$

Sursa de tensiune pentru $V_O > V_R$

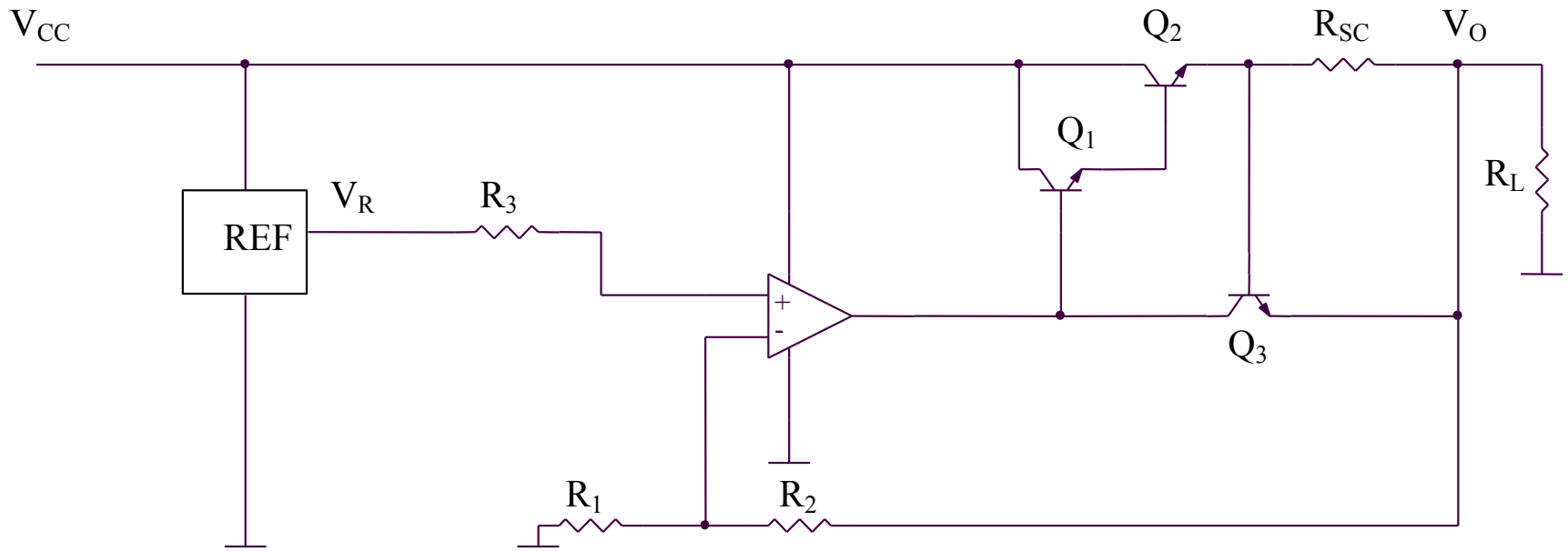

$$V_O \frac{R_1}{R_1 + R_2} = V_R \Rightarrow V_O = V_R \left(1 + \frac{R_2}{R_1} \right) > V_R$$

$$I_{Osc} = \frac{V_{BE}}{R_{sc}}$$

3.2.3. Surse de tensiune compensate cu temperatura

3.2.3. Surse de tensiune compensate cu temperatura

Referinte de tensiune bandgap (banda interzisa)

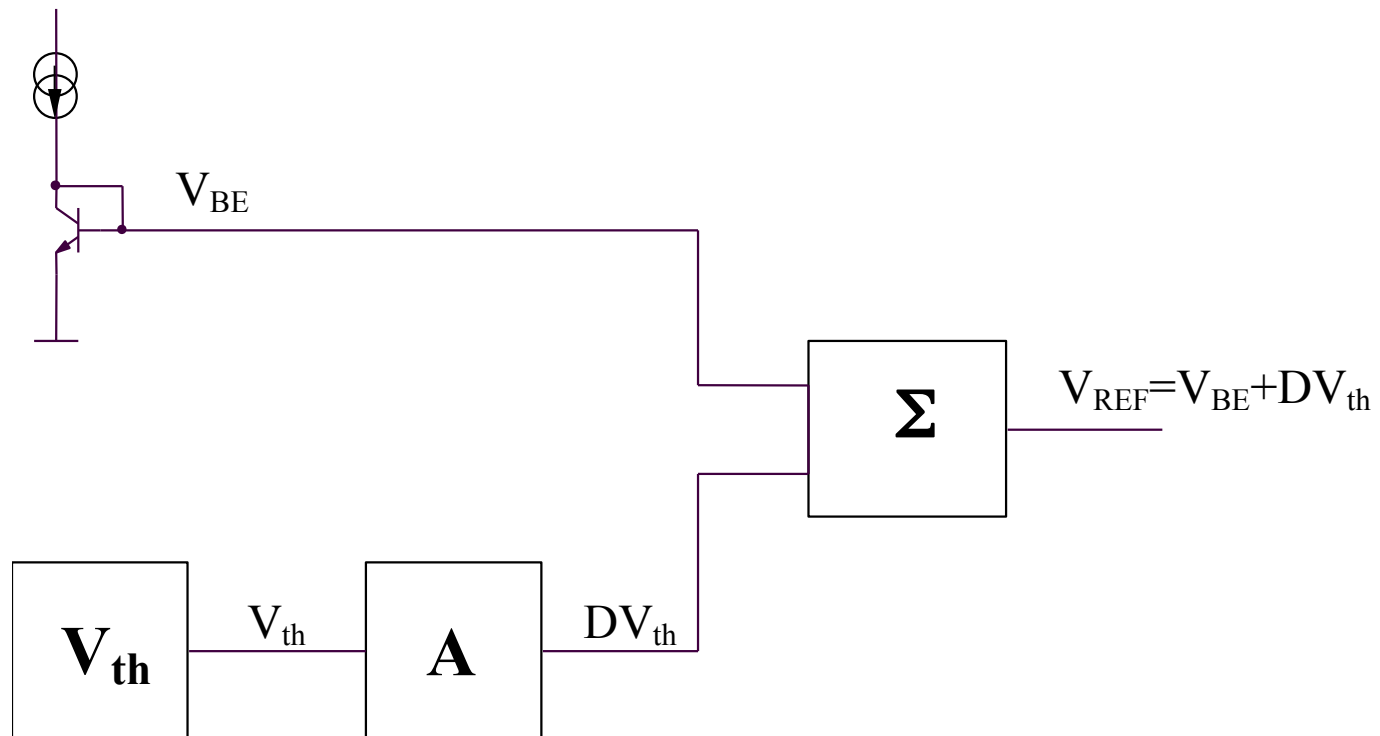

Dependenta de temperatura a tensiunii V_{BE}

$$\left. \begin{aligned} V_{BE}(T) &= V_{th} \ln \left[\frac{I_C(T)}{I_S(T)} \right] \\ I_S(T) &= CT^\eta \exp \left(-\frac{E_{GO}}{V_{th}} \right) \end{aligned} \right\} \Rightarrow \left. \begin{aligned} V_{BE}(T) &= E_{GO} + \frac{kT}{q} \ln \left[\frac{I_C(T)}{CT^\eta} \right] \\ V_{BE}(T_0) &= E_{GO} + \frac{kT_0}{q} \ln \left[\frac{I_C(T_0)}{CT_0^\eta} \right] \\ I_C(T) &= BT^\alpha \end{aligned} \right\} \Rightarrow$$

$$\Rightarrow V_{BE}(T) = E_{GO} + \frac{V_{BE}(T_0) - E_{GO}}{T_0} T + (\alpha - \eta) \frac{KT}{q} \ln \left(\frac{T}{T_0} \right)$$

$$\frac{V_{BE}(T_0) - E_{GO}}{T_0} \cong -2,1mV / K < 0$$

Functionarea referintelor de tensiune

$$\left. \begin{aligned} V_{REF}(T) &= DV_{th} + V_{BE}(T) \\ V_{BE}(T) &= A + BT + CT \ln\left(\frac{T}{T_0}\right) \end{aligned} \right\} \Rightarrow$$

$$\Rightarrow V_{REF}(T) = A + \left(B + D\frac{k}{q}\right)T + CT \ln\left(\frac{T}{T_0}\right)$$

$$B + D\frac{k}{q} = 0 \Rightarrow V_{REF}(T) = A + CT \ln\left(\frac{T}{T_0}\right)$$

Referinta de tensiune (1)

$$I_1 = \frac{V_{BE2} - V_{BE1}}{R_3} = \frac{kT}{qR_3} \ln\left(\frac{I_2}{I_1}\right) \Rightarrow$$

$$I_1 R_1 = I_2 R_2$$

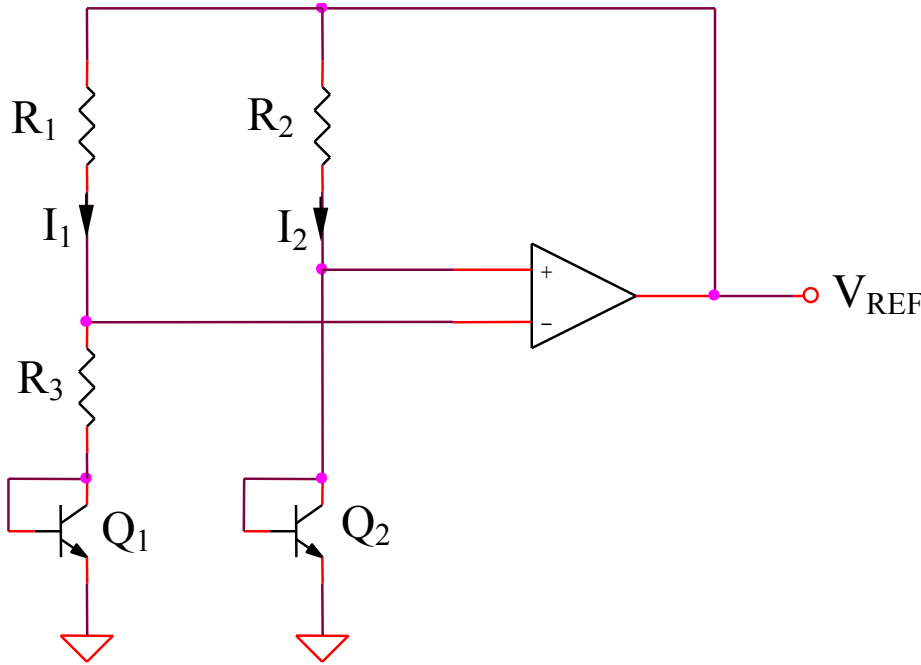

$$\Rightarrow I_1 = \frac{kT}{qR_3} \ln\left(\frac{R_1}{R_2}\right)$$

$$V_{REF}(T) = I_1(T)R_1 + V_{BE2}(T)$$

$$V_{BE}(T) = A + BT + CT \ln\left(\frac{T}{T_0}\right) \Rightarrow$$

$$\Rightarrow V_{REF}(T) = A + \left[B + \frac{k}{q} \frac{R_1}{R_3} \ln\left(\frac{R_1}{R_2}\right) \right] T + CT \ln\left(\frac{T}{T_0}\right)$$

$$B + \frac{k}{q} \frac{R_1}{R_3} \ln\left(\frac{R_1}{R_2}\right) = 0 \Rightarrow V_{REF}(T) = A + CT \ln\left(\frac{T}{T_0}\right) \cong A \cong 1,2V$$

V_{REF}

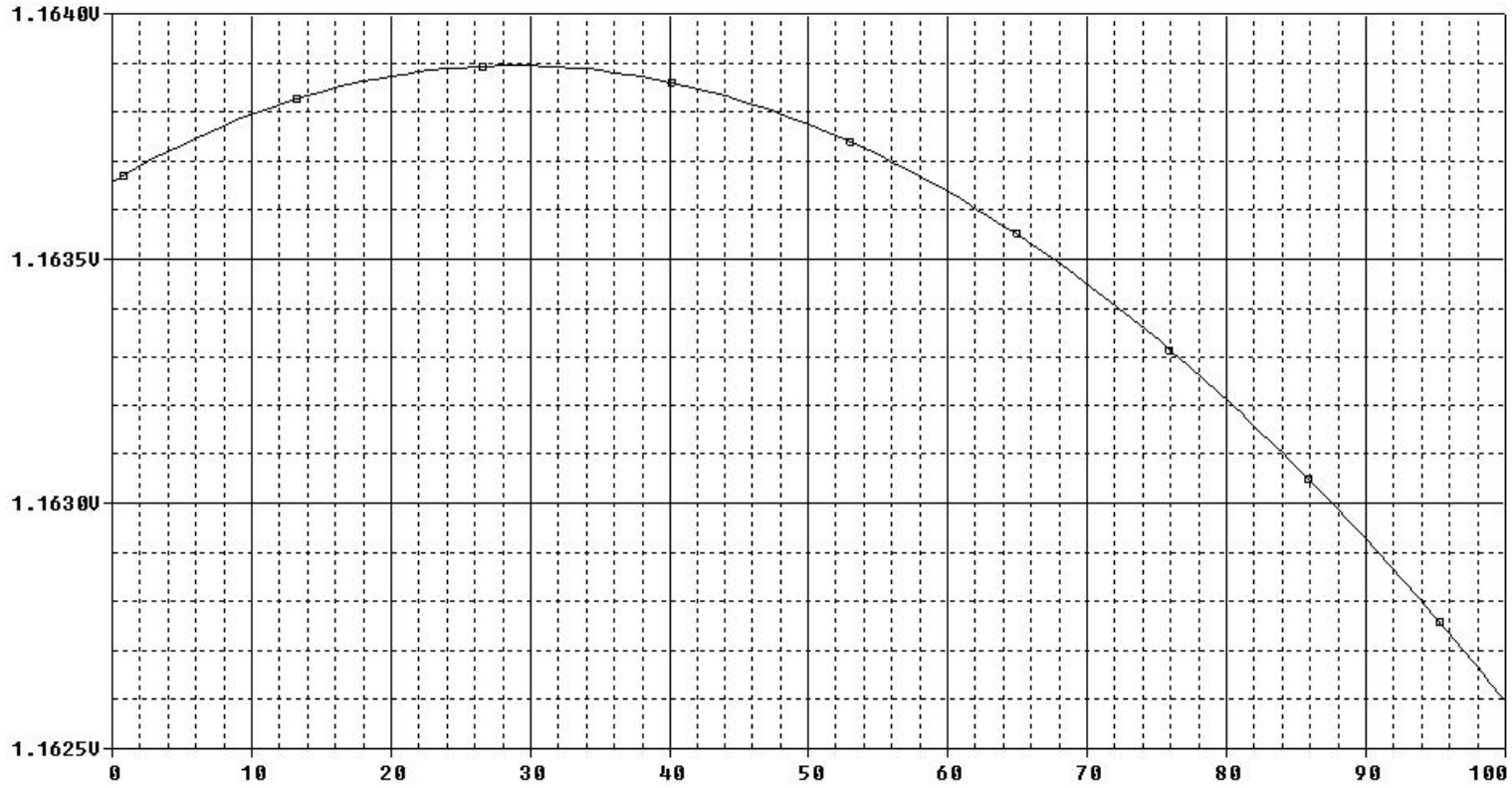

t

$$V_A - V_B = \sqrt{\frac{2I_{D5}}{K}} \left(1 - \sqrt{\frac{(W/L)_5 (W/L)_6}{(W/L)_4 (W/L)_7}} \right)$$

Pentru: $\frac{(W/L)_4}{(W/L)_5} = \frac{(W/L)_6}{(W/L)_7} \Rightarrow V_A = V_B$

$$\Rightarrow V_O(T) = /V_{BE_3}(T)/ + I(T)R_2 = /V_{BE_3}(T)/ + \frac{/V_{BE_1}(T)/ - /V_{BE_2}(T)/}{R_1} R_2$$

$$V_O(T) = /V_{BE_3}(T)/ + \frac{R_2}{R_1} \frac{kT}{q} \ln \frac{I_{D6}}{I_{D7}}$$

$$V_O(T) = /V_{BE_3}(T)/ + \frac{R_2}{R_1} \frac{kT}{q} \ln \left[\frac{(W/L)_6}{(W/L)_7} \right]$$

$$\left. \begin{array}{l} /V_{BE}(T)/ = A + BT + CT \ln \left(\frac{T}{T_0} \right) \\ B + \frac{R_2}{R_1} \frac{k}{q} \ln \left[\frac{(W/L)_6}{(W/L)_7} \right] = 0 \end{array} \right\} \Rightarrow V_O(T) = A + CT \ln \left(\frac{T}{T_0} \right)$$

SIMULARE pentru referinta de tensiune (2)
Dependentă de temperatura a tensiunii de referință

SIMULARE pentru referinta de tensiune (2)

Dependenta de temperatura a tensiunii de referinta

SIM 3.13: $V_{D5}(t)$

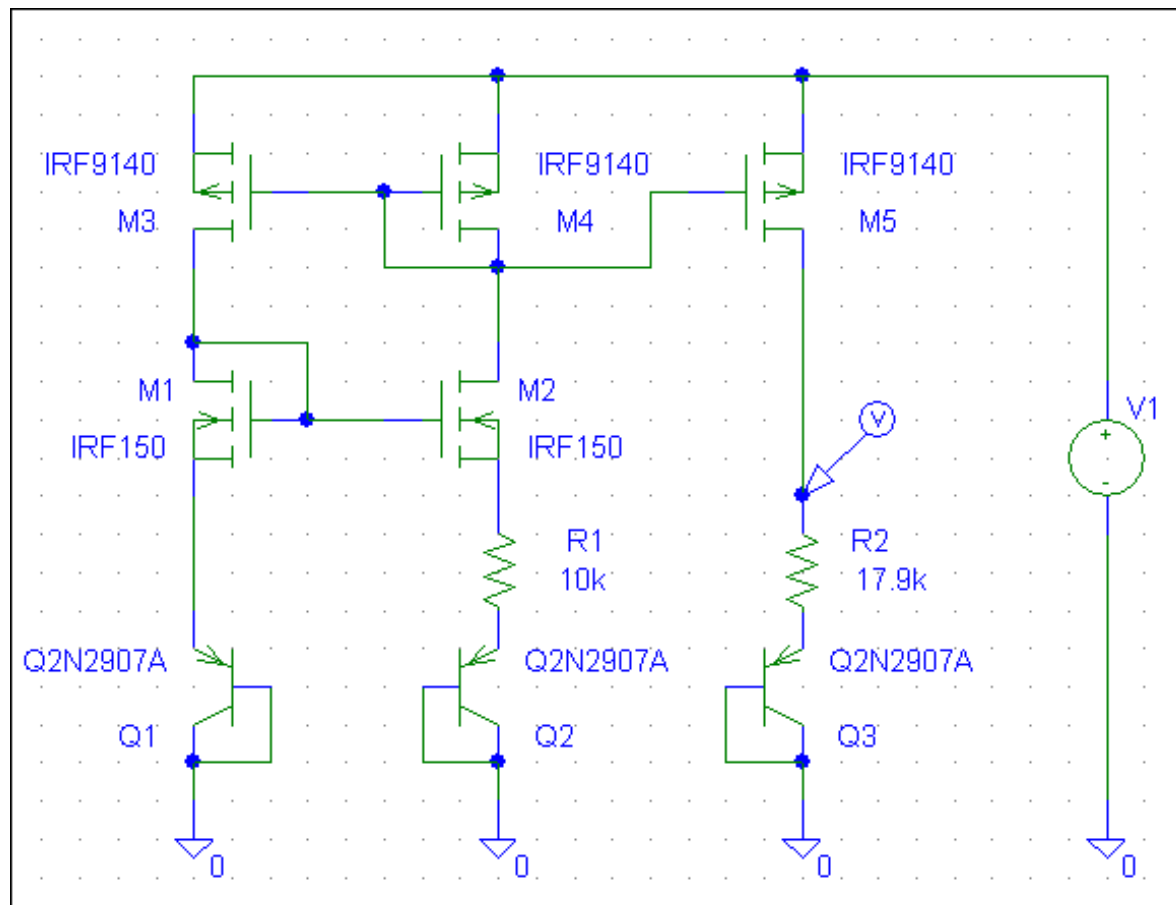

Referinta de tensiune (3)

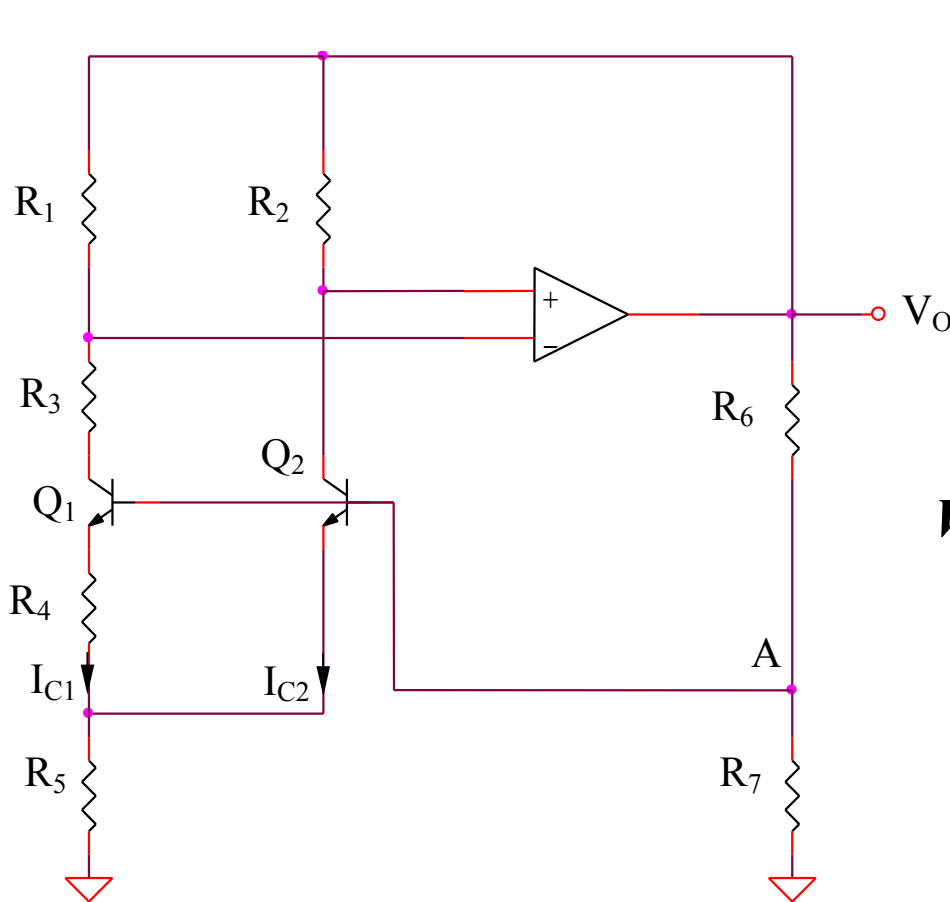

$$I_{C1} = \frac{V_{BE2} - V_{BE1}}{R_4} = \frac{V_{th}}{R_4} \ln \frac{I_{C2}}{I_{C1}} \Rightarrow I_{C1} R_1 = I_{C2} R_2$$

$$\Rightarrow I_{C1} = \frac{V_{th}}{R_4} \ln \frac{R_1}{R_2}$$

$$V_A(T) = (I_{C1} + I_{C2})R_5 + V_{BE2}(T)$$

$$V_A(T) = V_O(T) \frac{R_7}{R_6 + R_7} \Rightarrow$$

$$\Rightarrow V_O(T) = \left(1 + \frac{R_6}{R_7} \right) \left[V_{BE2}(T) + \frac{R_5}{R_4} \left(1 + \frac{R_1}{R_2} \right) V_{th} \ln \left(\frac{R_1}{R_2} \right) \right]$$

$$\frac{R_5}{R_4} \left(1 + \frac{R_1}{R_2} \right) \frac{k}{q} \ln \left(\frac{R_1}{R_2} \right) + B = 0 \Rightarrow V_O(T) = \left(1 + \frac{R_6}{R_7} \right) \left[A + CT \ln \left(\frac{T}{T_0} \right) \right]$$

Senzori de temperatura

Exemplu (1)

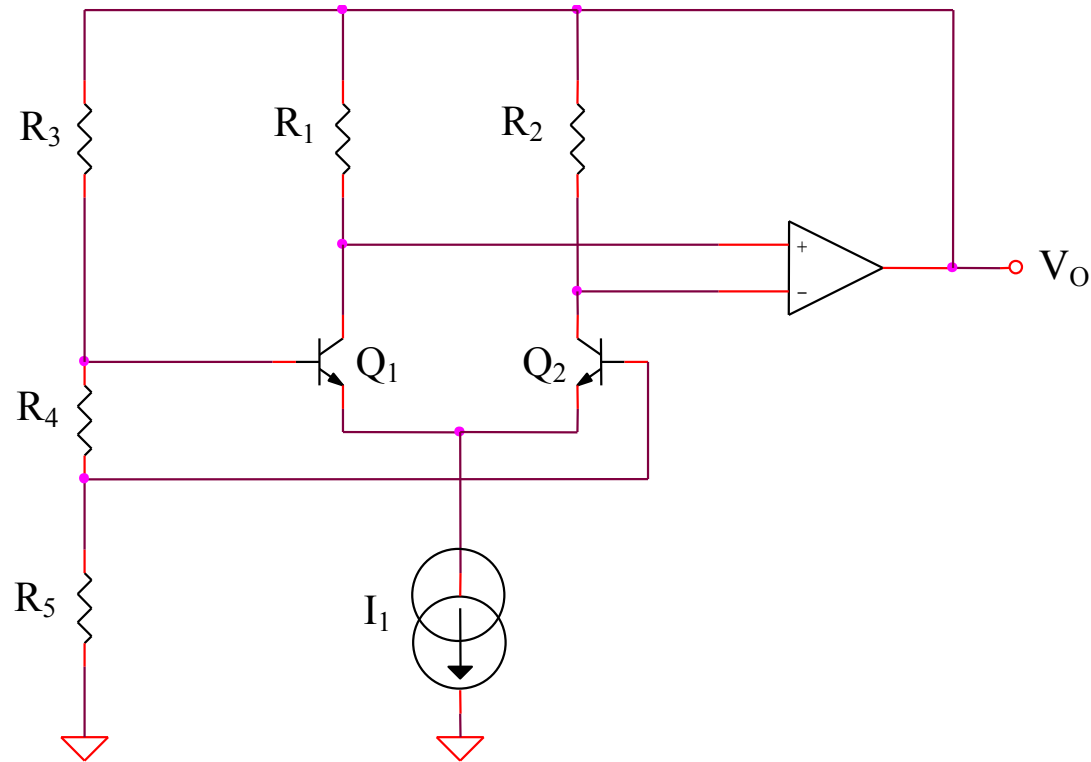

$$V_O(T) \frac{R_4}{R_3 + R_4 + R_5} = V_{BE1} - V_{BE2} = V_{th} \ln \frac{I_{C1}}{I_{C2}} = V_{th} \ln \frac{R_2}{R_1} \Rightarrow$$

$$\Rightarrow V_O(T) = \left(1 + \frac{R_3 + R_5}{R_4} \right) V_{th} \ln \left(\frac{R_2}{R_1} \right) = ct.T$$

Exemplu (2)

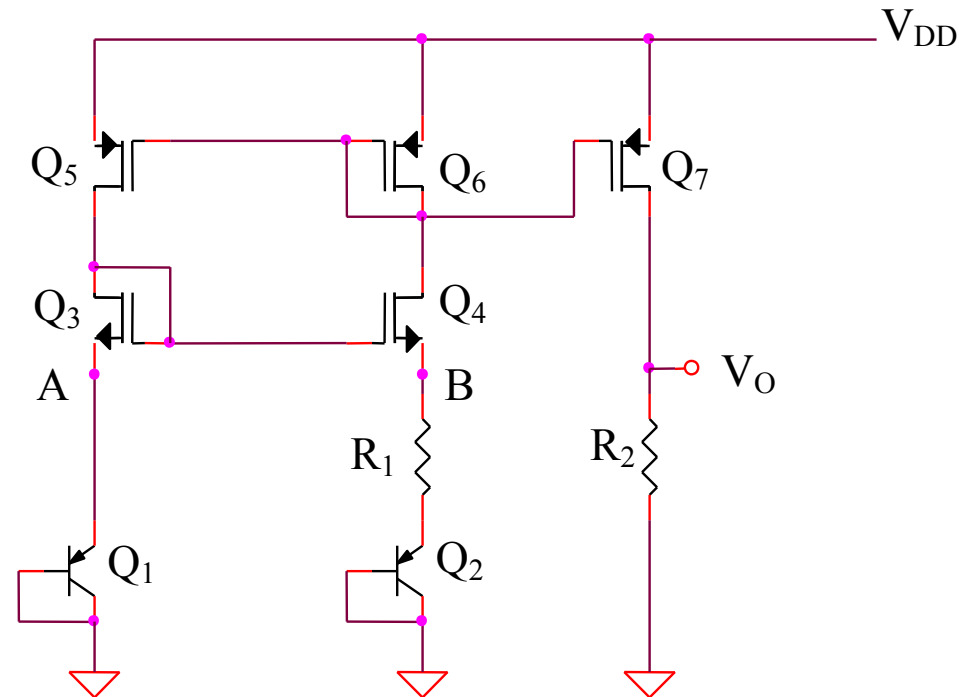

$$V_O = R_2 I_{D7}(T) = R_2 I_{D4}(T) = R_2 \frac{|V_{BE1}| - |V_{BE2}|}{R_1} = \frac{R_2}{R_1} V_{th} \ln \left[\frac{(W/L)_5}{(W/L)_6} \right] = ct \cdot T$$

Exemplu (3) – circuit de extragere a tensiunii de prag

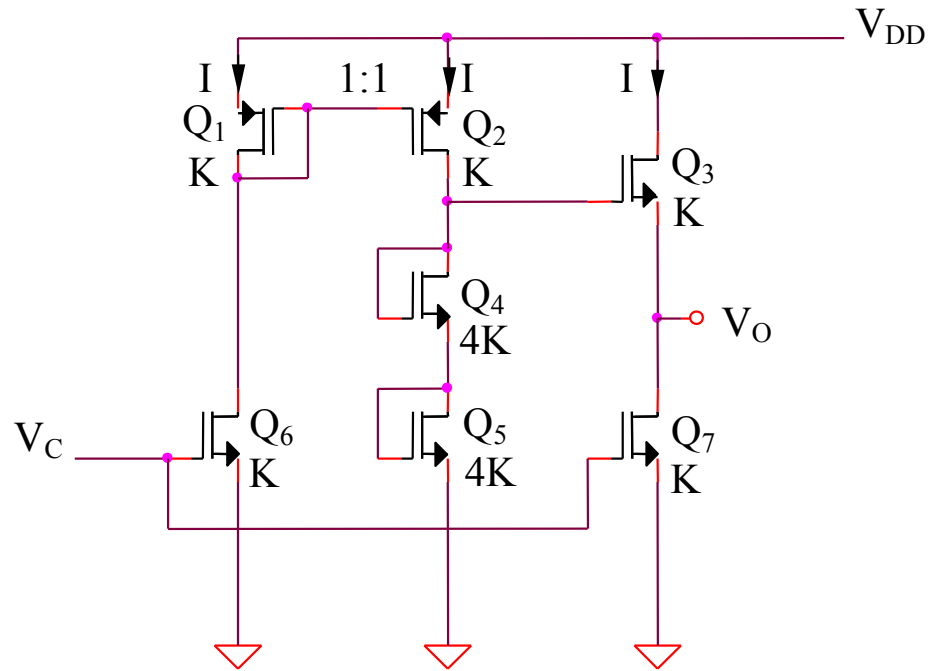

$$V_O = 2V_{GS_4} - V_{GS_3} = 2\left(V_T + \sqrt{\frac{2I}{4K}}\right) - \left(V_T + \sqrt{\frac{2I}{K}}\right) = V_T = V_{T0} + a(T - T_0)$$